

July 28, 2023

PERFORMANCE BULLETIN 138

K526 Valve Cap-to-Body Oring Removed

The K526 valve Cap and Body are being updated to eliminate the need for an Oring to seal against the Diaphragm. The updated Body and Cap surfaces facing the Diaphragm will now be machined to assure a flat surface which will positively seal against the Diaphragm. Previously, an Oring was required between the parts because it was difficult to maintain flatness on molded surfaces this large.

As a result of this change, Oring PN 1071713, item 9 in drawing below will no longer be required.

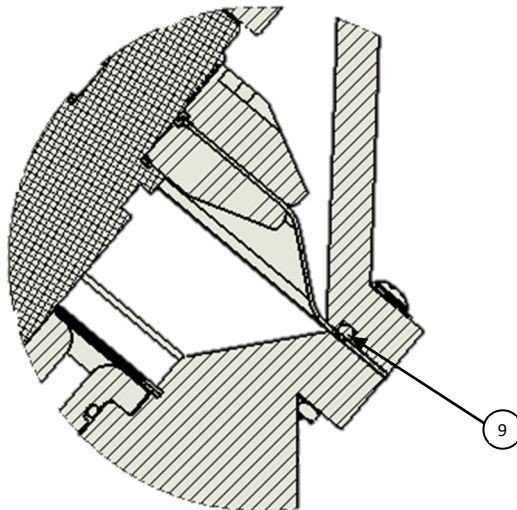

The Oring PN 1071713 will remain in Diaphragm and Seal Kits for the foreseeable future but will not be required if repairing valves with machined flat Cap and Body. The update will be implemented when inventory of the current version is exhausted.



AQMATIC
Valves & Controls

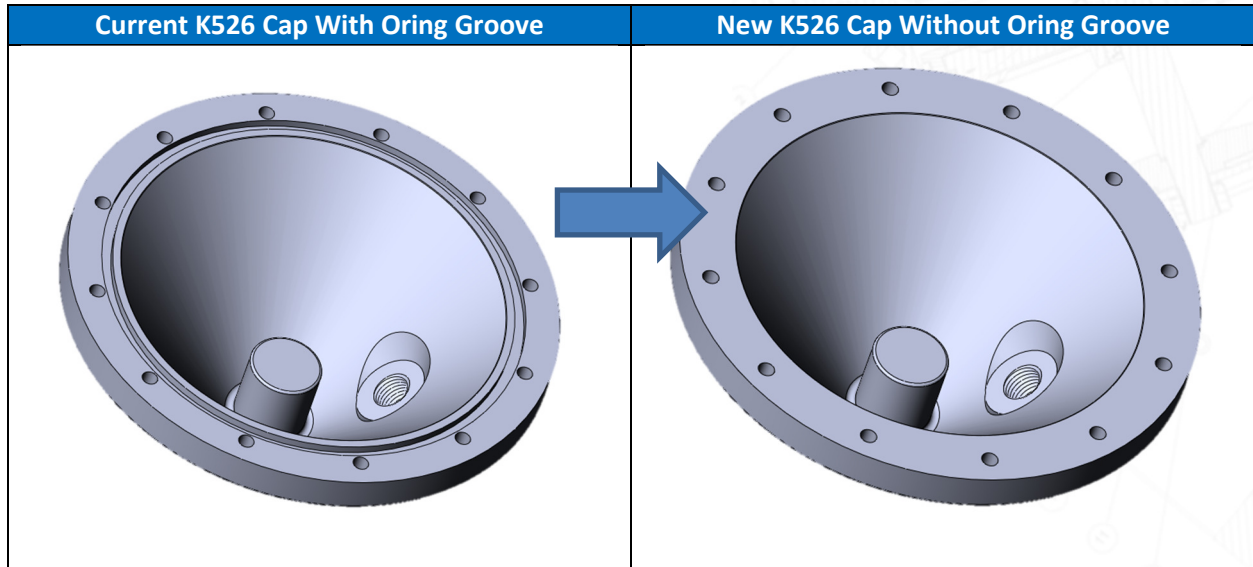

If any questions should arise, please contact us at TechSupport@AQ-Matic.com or +1-262-326-0100.