

4

3

2

1

REPAIR PARTS KITS

DESCRIPTION	PART NO.		
DIAPHRAGM & SEALS KIT CONSIST OF ITEM NO'S 3(2), 5, 6, 8 , 9, 14, 16	1070068 (421-RA) BUNA N INCLUDES DIAPHRAGM 1074119 (421-FB)	1070081 (421-RAE) E.P.D.M. INCLUDES DIAPHRAGM 1074119 (421-FB)	1070093 (421-RAV) FKM INCLUDES DIAPHRAGM 1074120 (421-FV)
INT. PARTS KIT (NORM. OPEN) CONSIST OF STANDARD ITEM NO'S 4, 7, 10,11(2)	1070118 (421-RF)		
SEAT (ITEM NO. 2)	1074158 (421-MO)		

ASSEMBLY TOOLS

DESCRIPTION	PART NO.
FOR INSTALLATION AND REMOVAL OF SEAT (ITEM #2) (TOOL NOT SHOWN)	1074161 (421-MT)
FOR INSTALLATION AND REMOVAL OF SHAFT GUIDE (ITEM #10) (TOOL NOT SHOWN)	1074124 (421-GT)

TORQUE TABLE

ITEM #	DESCRIPTION	TORQUED TO (+/- 10%)
2	SEAT	120 IN/LBS
3	UPPER NUT	90 IN/LBS
3	LOWER NUT	90 IN/LBS
10	GUIDE, SHAFT	120 IN/LBS
13 & 15	NUT, & CAP SCREW	140 IN/LBS

NOTES:

- AMERICAN NATIONAL STANDARD TAPER PIPE THREADS (NPT) PER ANSI B2. 1-1968
- VALVES AVAILABLE WITH B.S.P.T END CONNECTIONS

REVISIONS

ECN	REV.	DESCRIPTION	DATE	APPROVED
1791	U	CATALOG SHEET UPDATE, COMPONENT CHANGES	10/15/20	TRK
2041	V	CATALOG SHEET UPDATE, COMPONENT CHANGES	3/17/22	TRK
2222	W	CATALOG SHEET UPDATE, COMPONENT CHANGES	4/13/23	TRK

ITEM NO.	DESCRIPTION	STD.	PART NUMBER	QTY.	
1	BODY, CAST IRON	CAST IRON	3/4" NPT	1074085 (421-A3)	1
			1" NPT	1074088 (421 - A4)	
		CAST BRASS	3/4" NPT	1074077 (421 - AB3)	
			1" NPT	1074080 (421 - AB4)	
		CAST IRON	3/4" BSP	1074086	
		1" BSP	1074089		
		CAST BRASS	1" BSP	11074081	
2	SEAT (REQ'S ASSY TOOL)	BRASS	1074158 (421-M0)	1	
3	HEX NUT, 1/4"-28	SS	1263852 (NUS-0100)	2	
4	DISC PLATE	SS	1074149 (421-SC)	1	
5	O-RING, 2-024	BUNA	1071676 (ORB-024)	1	
		EPDM	1071721 (ORE-024)		
		FKM	1071791 (ORV-024)		
6	DISC	BUNA	1074140 (421-J)	1	
		EPDM	1074143 (421-JE)		
		FKM	1074146 (421-JV)		
		HYCAR	1074144 (421-JH)		
7	COMBINATION SHAFT, 421	SS	4510231	1	
8	WASHER,PLAIN,5/16" X .60 OD	COPPER	1073948	1	
9	O-RING , 2-125	BUNA	1071693 (ORB-125)	1	
		EPDM	1071732 (ORE-125)		
		FKM	1071803 (ORV-125)		
10	SHAFT GUIDE	SS	1074123	1	
11	DISC PLATE	SS	43942 (424-H)	2	
12	CAP,NPT TAP TOP	CAST IRON	1074093 (421-C)	1	
		BRASS	1074096 (421-CB)		
13	HEX SCREW, 1/4 - 20	PLATED STEEL	1072398 (SCZ-0004)	4	
		SS	1080720 (SCS-0142)		
14	DIAPHRAGM, 421	BUNA	1074119 (421-FB)	1	
		FKM	1074120 (421-FV)		
15	HEX NUT, 1/4 - 20	PLATED STEEL	1071656 (NUZ-0008)	4	
		SS	1071649 (NUZ-007)		
		BUNA	1071689 (ORB-110TC)		
16	O-RING 2-110 (TEFLON COATED)	EPDM	1071726 (ORE-110TC)	1	
		FKM	1239021 (ORV-110)		

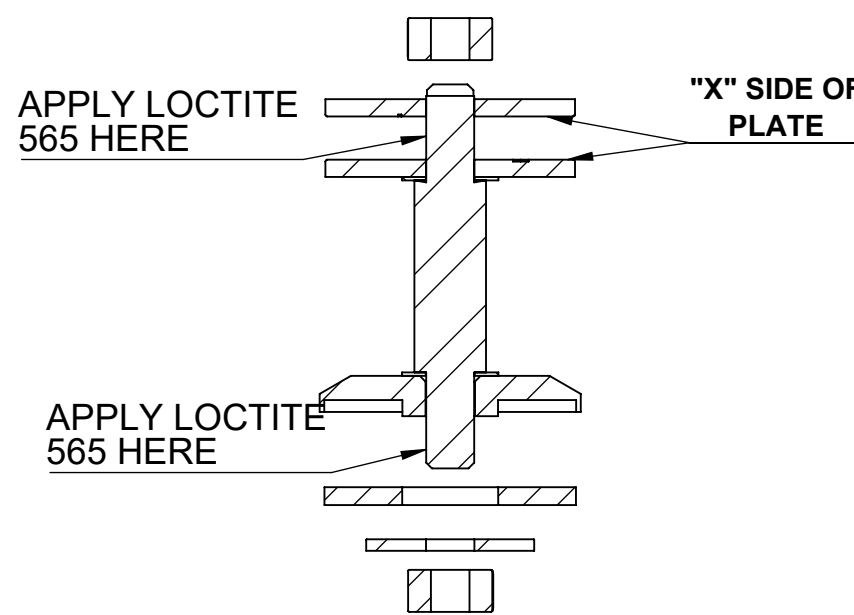
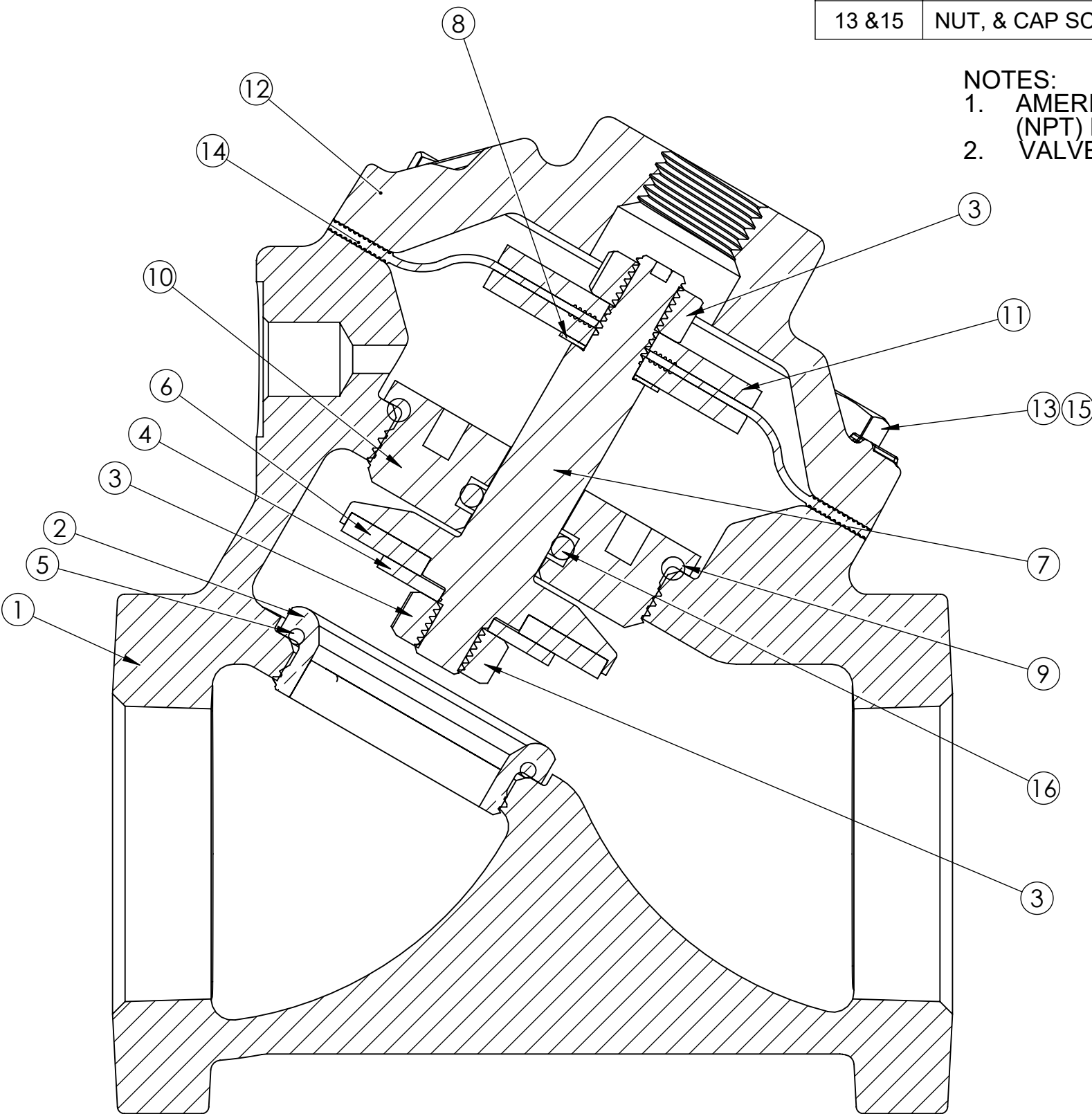
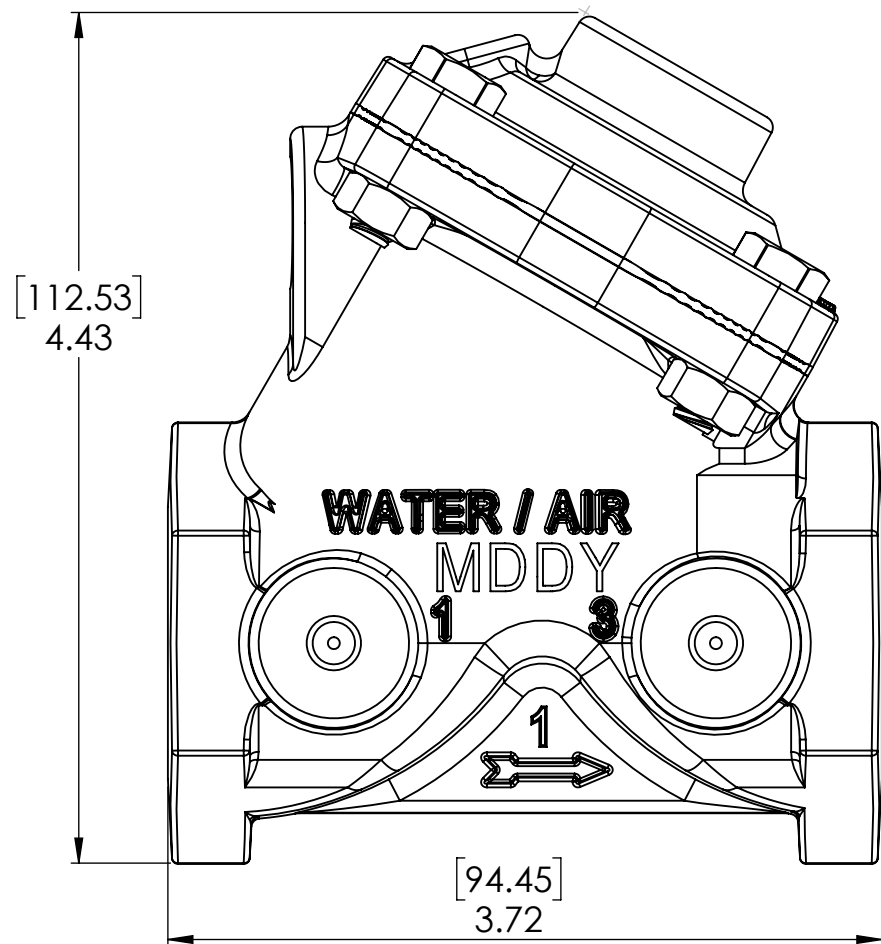

SEE REVERSE SIDE FOR CONFIGURATION OPTIONS

1070001 (V42B-0000-00000) (3/4" NPT)
 1070011 (V42C-0000-00000) (1" NPT)
NORMALLY OPEN STANDARD MODEL

THIS DOCUMENT IS SOLELY THE PROPERTY OF AQ-MATIC REPRODUCTION, USE DISCLOSURE, OR TRANSMISSION OF THIS DOCUMENT OR DETAILS CONTAINED HEREIN, IN PART OR IN WHOLE, IS PROHIBITED WITHOUT THE WRITTEN CONSENT OF AQ-MATIC ENGINEERING. THIS DOCUMENT AND ANY COPIES SHALL BE RETURNED TO AQ-MATIC UPON WRITTEN REQUEST.

DO NOT SCALE DRAWING. DIMS. ARE IN INCHES [mm]
 INTERPRET DIMS AND TOLERANCES PER ASME Y14.5M -1994
 UNLESS OTHERWISE SPECIFIED:
 CORNER FILLETS R.005-.020 [.127-.508]
 TOLERANCES:
 ANGLES : ± 1°
 1 PLACE .X: ± .015 [0.38]
 2 PLACE .XX: ± .01 [0.3]
 3 PLACE .XXX: ± .005 [0.13]

THE COMPONENT, PART, OR ASSEMBLY DESCRIBED IN THIS DOCUMENT MUST COMPLY WITH THE EU (EUROPEAN UNION) DIRECTIVE: RoHS DIRECTIVE 2011/65/EC.

THIRD ANGLE PROJECTION

APPROVALS DATE

DRAWN TRK 10/15/20

CHECKED BY

APPROVED



CATALOG SHEET, 421
 DIAPHRAGM VALVE STANDARD MODEL

SCALE DWG NO. 1077613 REV. W
 SOLIDWORKS FORMAT SHEET 1 OF 2

4

3

2

1

REVISIONS				
ECN	REV.	DESCRIPTION	DATE	APP'D
SEE PAGE 1 FOR REV. CHANGES				

D

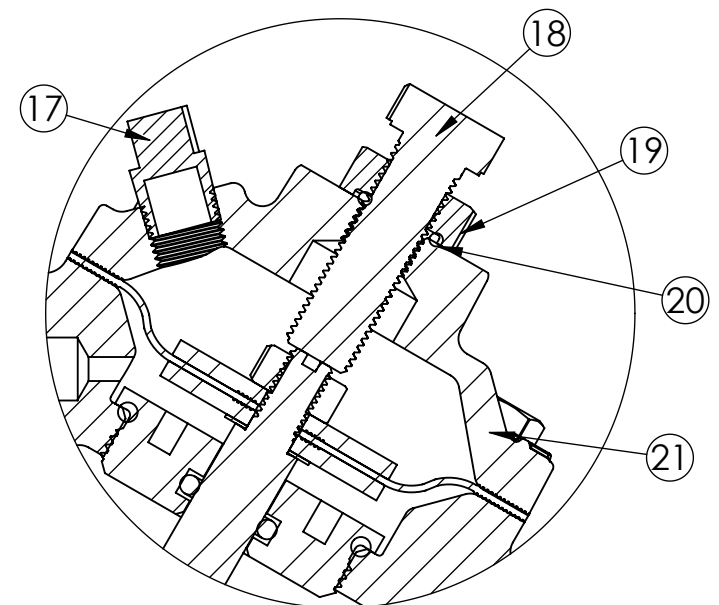

1072563 (V42B-0010-00000) (3/4' NPT)
 1070015 (V42C-0010-00000) (1" NPT)
LIMIT STOP MODEL

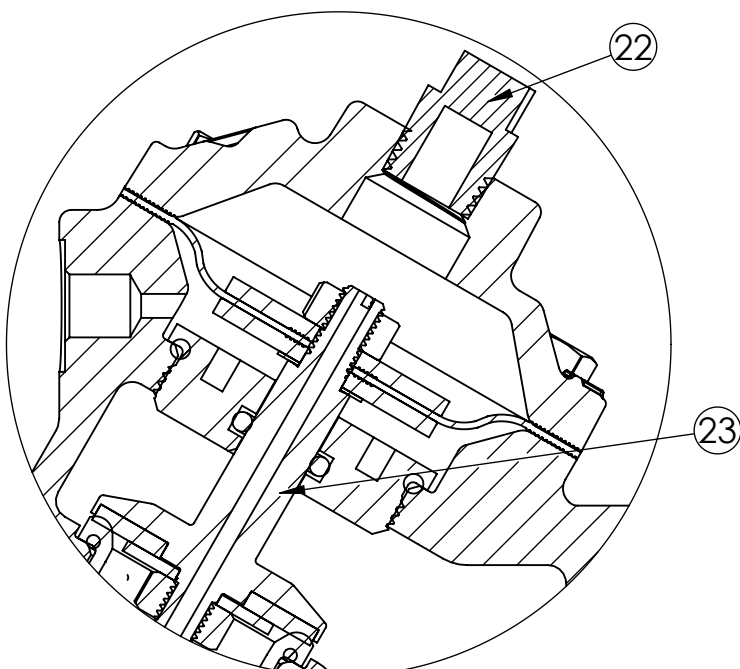

1070002 (V42B-0030-00000) (3/4' NPT)
 1070012 (V42C-0030-00000) (1" NPT)
NORMALLY CLOSED MODEL

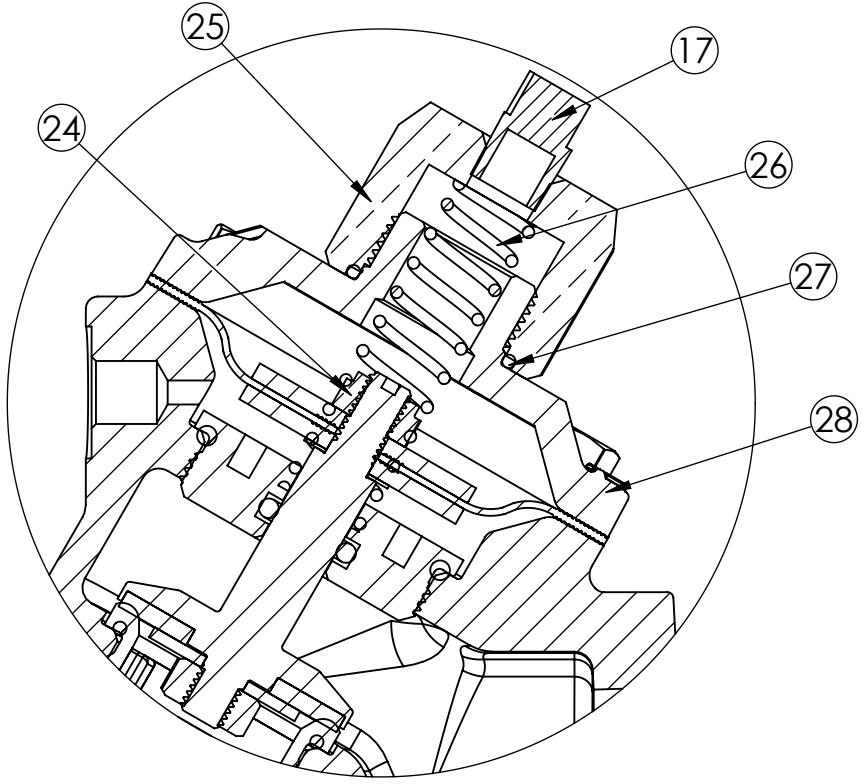

1070001 (V42B-0002-00000) (3/4' NPT)
 1070011 (V42C-0002-00000) (1" NPT)
SPRING ASSIST CLOSED MODEL

C

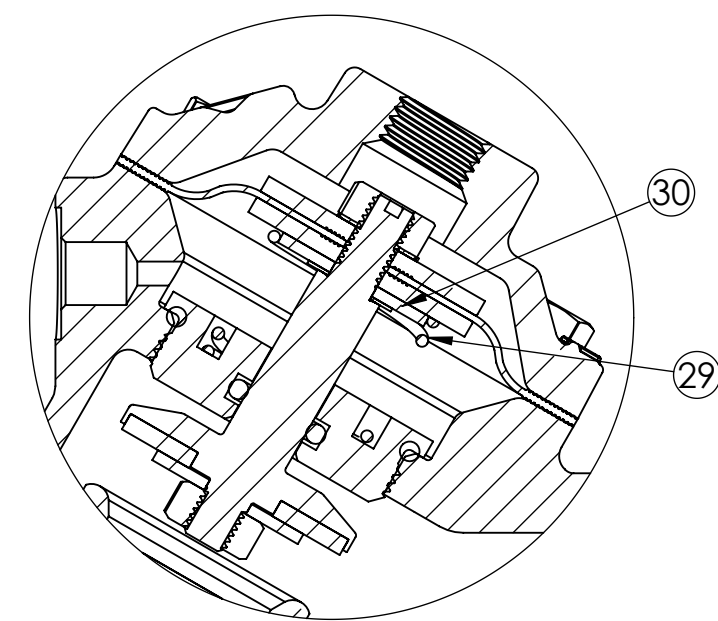

1070004 (V42B-0001-00000) (3/4' NPT)
 1070014 (V42C-0001-00000) (1" NPT)
SPRING ASSIST OPEN MODEL

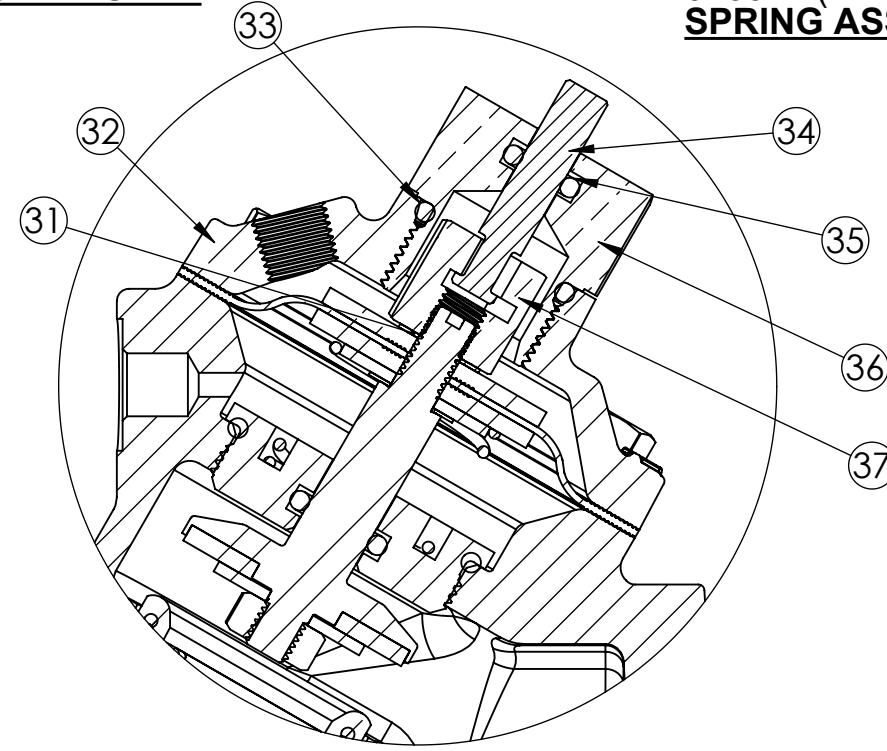

1070144 (V42B-0021-00000) (3/4' NPT)
 1072648 (V42C-0021-00000) (1" NPT)
POSITION INDICATOR MODEL

LIMIT STOP MODEL

ITEM NO.	DESCRIPTION	STD.	PART NUMBER	QTY.
17	PIPE PLUG (1/8" NPT)	PLATED STEEL	* 1071917 (PLZ-0005)	1
		BRASS	1071903 (PLB-0007)	
18	SCREW, HEX HEAD	SS	* 1072361 (SCS-0030)	1
19	HEX NUT	SS	* 4510459 (400-H)	1
20	O-RING, 2-012	BUNA	* 1071668 (ORB-012)	1
21	CAP, LIMIT STOP W/ NPT PORT	CAST IRON	* 1074101 (421-CCC)	1
		BRASS	1074104 (421-CCCB)	

NORMALLY CLOSED MODEL

ITEM NO.	DESCRIPTION	STD.	PART NUMBER	QTY.
22	PIPE PLUG (1/4"NPT)	PLATED STEEL	* 1071918 (PLZ-0008)	1
		BRASS	1071904(PLB-0009)	
23	COMBINATION SHAFT, 421, NC	SS	* 4510232	1

SPRING ASSIST CLOSED MODEL

ITEM NO.	DESCRIPTION	STD.	PART NUMBER	QTY.
24	CENTERING NUT	SS	* 1074185 (421-X)	1
25	RETAINER NUT	BRASS	* 1074183 (421-TT)	1
26	COMPRESSION SPRING	SS	* 1078602 (421-SS)	1
27	O-RING, 2-020	BUNA	* 1071674 (ORB-020)	1
28	CAP, SPRING ASSIST CLOSED	CAST IRON	* 1074099 (421-CC)	1
		BRASS	1074100 (421-CCB)	

SPRING ASSIST OPEN MODEL

ITEM NO.	DESCRIPTION	STD.	PART NUMBER	QTY.
29	SPRING	SS	* 1078608	1
30	DISC PLATE	SS	* 1074149 (421-SC)	1

POSITION INDICATOR MODEL

ITEM NO.	DESCRIPTION	STD.	PART NUMBER	QTY.
31	LOCKWASHER	SS	* 1073589 (WAS-0006)	1
32	CAP, POSITION INDICATOR W/ NPT PORT	CAST IRON	* 1074107 (421-CF)	1
		BRASS	1074110 (421-CF)	
33	O-RING, 2-116	BUNA	* 1071692 (ORB-116)	1
34	P.I. INDICATOR ROD	SS	* 1074164 (421-PM)	1
35	O-RING, 2-108	BUNA	* 1071688 (ORB-108TC)	1
36	SHAFT GUIDE BUSHING	BRASS	* 1074121 (421-GF)	1
37	TOP NUT	BRASS	* 1074182 (421 421-TB)	1

CONVERSION KITS

DESCRIPTION	PART NO.
CONVERSION KIT (LIMIT STOP) CONSISTS OF STANDARD ITEM NO'S 18 THRU 21	1074155 (421-LSC)
CONVERSION KIT (SPRING ASSIST CLOSED) CONSISTS OF STANDARD ITEM NO'S 24 THRU 28	1074177 (421-SCC)
CONVERSION KIT (SPRING ASSIST OPEN) CONSISTS OF STANDARD ITEM NO'S 4, 8,10, 29, 30	1074179 (421-SOC)
CONVERSION KIT (POSITION INDICATOR) CONSISTS OF STANDARD ITEM NO'S 31 THRU 37	1074163 (421-PIC)

TORQUE TABLE

ITEM #	DESCRIPTION	TORQUED TO (+/- 10%)
19	NUT, LIMIT STOP	90 IN/LBS
24	CENTERING NUT	90 IN/LBS
25	NUT, SPRG RETAINER	120 IN/LBS
36	PI ROD GUIDE	120 IN/LBS
37	TOP NUT, PI	90 IN/LBS

- NOTES:
 1. SPRING ASSIST CLOSED MODEL CANNOT BE COMBINED WITH LIMIT STOP MODEL.
 2. VALVES AVAILABLE WITH B.S.P.T END CONNECTIONS.

REPAIR PARTS KITS

DESCRIPTION	PART NO.
INT. PARTS KIT (LIMIT STOP) CONSISTS OF STANDARD ITEM NO'S 18, 19, 20	1074154 (421-LS)
INT. PARTS KIT (NORM. CLOSED) CONSISTS OF STANDARD ITEM NO'S 4, 11(2), 23	1070129 (421-RG)
INT. PARTS KIT (SPRING ASSIST CLOSED) CONSISTS OF STANDARD ITEM NO'S 24, 26, 27	1074176 (421-SC)
INT. PARTS KIT (SPRING ASSIST OPEN) CONSISTS OF STANDARD ITEM NO'S 8, 29, 30	1074178 (421-SO)
INT. PARTS KIT (POSITION INDICATOR) CONSISTS OF STANDARD ITEM NO'S 31, 33 THRU 37	1074162 (421-PI)

SEE REVERSE SIDE FOR STANDARD NORMALLY OPEN MODEL

THIS DOCUMENT IS SOLELY THE PROPERTY OF AQ-MATIC REPRODUCTION, USE DISCLOSURE, OR TRANSMISSION OF THIS DOCUMENT OR DETAILS CONTAINED HEREIN, IN PART OR IN WHOLE, IS PROHIBITED WITHOUT THE WRITTEN CONSENT OF AQ-MATIC ENGINEERING. THIS DOCUMENT AND ANY COPIES SHALL BE RETURNED TO AQ-MATIC UPON WRITTEN REQUEST.

DO NOT SCALE DRAWING. DIMS. ARE IN INCHES [mm] INTERPRET DIMS AND TOLERANCES PER ASME Y14.5M -1994 UNLESS OTHERWISE SPECIFIED:
 CORNER FILLETS R.005-.020 [.127-.508]
 TOLERANCES:
 ANGLES: ± 1°
 1 PLACE .X: ± .015 [0.38]
 2 PLACE .XX: ± .01 [0.3]
 3 PLACE .XXX: ± .005 [0.13]

THE COMPONENT, PART, OR ASSEMBLY DESCRIBED IN THIS DOCUMENT MUST COMPLY WITH THE EU (EUROPEAN UNION) DIRECTIVE: RoHS DIRECTIVE 2011/65/EC.

THIRD ANGLE PROJECTION	
APPROVALS	DATE
DRAWN TRK	10/15/20
CHECKED BY	
APPROVED	

AQ Matic

CATALOG SHEET, 421
 DIAPHRAGM VALVE STANDARD MODEL

DWG NO. 1077613 REV. W

SCALE SOLIDWORKS FORMAT SHEET 1 OF 2

A

A

B

B

C

C

D

D