

REPAIR PARTS KITS			
DESCRIPTION	PART NO.		
DIAPHRAGM & SEALS KIT CONSISTS OF ITEM NO'S 3(2),5,6,7,8,13,15(2)	1070071 (426-RA)	1070084 (426-RAE)	1070096 (426-RAV)
	BUNA N INCLUDES DIAPHRAGM 1074374 (426-FB)	EPDM INCLUDES DIAPHRAM 1074374 (426-FB)	FKM INCLUDES DIAPHRAM 1074376 (426-FV)
INT. PARTS KIT (NORM. OPEN) CONSISTS OF STANDARD ITEM NO'S 4,9,10(2),16	1070121(426-RF)		
SEAT (ITEM NO. 2)	1074409 (426-MO)		

ASSEMBLY TOOLS	
DESCRIPTION	PART NO.
FOR INSTALLATION & REMOVAL OF SEAT (ITEM #2) (TOOL NOT SHOWN)	1074411 (426-MT)
FOR INSTALLATION & REMOVAL OF SHAFT GUIDE (ITEM #9) (TOOL NOT SHOWN)	1-1/4" HEX SOCKET

REVISIONS				
ECN	REV.	DESCRIPTION	DATE	APP'D
1254	X	COMPONET UPDATE, PART TO PRINT	1/14/21	
2072	Y	COMPONET UPDATE, PART TO PRINT	5/10/22	

TORQUE TABLE		
ITEM #	DESCRIPTION	TORQUED TO (+/- 10%)
2	SEAT	200 IN/LBS
3	UPPER NUT	140 IN/LBS
3	LOWER NUT	140 IN/LBS
9	SHAFT GUIDE	200 IN/LBS
12 & 14	NUT, HEX SCREW	140 IN/LBS

NO.	DESCRIPTION	STD	PART NO.	QTY	
1	BODY	CAST IRON	2" NPT	1074343 (426-A8)	1
			2 1/2" NPT	1081559 (426-A10)	
			2" BSP	1074344 (426-A8-BSP)	
	CAST BRASS	2" NPT	1074338 (426-AB8)		
		2 1/2" NPT	1074335 (426-AB10)		
		2.50" BSP	1074341 (426-A10-BSP)		
2	SEAT; BRASS (REQ'S ASSY TOOL)	*	1074409 (426-M0)	1	
3	HEX NUT (5/16-24)	*	1263853 (RMET)	2	
4	DISC PLATE, SS		4510417	1	
5	O-RING	BUNA N	1071696 (ORB-144)	1	
		EPDM	1071737 (ORE-144)		
		FKM	1071809 (ORV-144)		
6	DISC	BUNA	1074389 (426-J)	1	
		EPDM	1074391 (426-JE)		
		FKM	1074394 (426-JV)		
		HYCAR	1074392 (426-JH)		
7	GASKET, COPPER	*	1074252 (424-R)	1	
8	O-RING	BUNA N	1071706 (ORB-233)	1	
		EPDM	1071754 (ORE-233)		
		FKM	1071826 (ORV-233)		
9	SHAFT GUIDE (REQ'S ASSY TOOL)	*	43849	1	
10	DIAPHRAGM PLATE; SS	*	1074371 (426-DA)	2	
11	CAP	CAST IRON	1081560 (426-C)	1	
		CAST BRASS	1074348 (426-CB)		
12	HEX SCREW	PLATED STEEL	1072401 (SCZ-0015)	6	
		SS	1072358 (SCS-0016)		
13	DIAPHRAGM	BUNA N	1074374 (426-FB)	1	
		FKM	1074376 (426-FV)		
14	HEX NUT	PLATED STEEL	1071657 (NUZ-0011)	6	
		SS	1071655(NUS-0035)		
15	O-RING	BUNA N	1071691 (ORB-114TC)	2	
		EPDM	1071729 (ORE-114TC)		
		FKM	1242391 (ORV-114TC)		
16	COMBINATION SHAFT (NORMALLY OPEN)	*	44021 (426-L)	1	

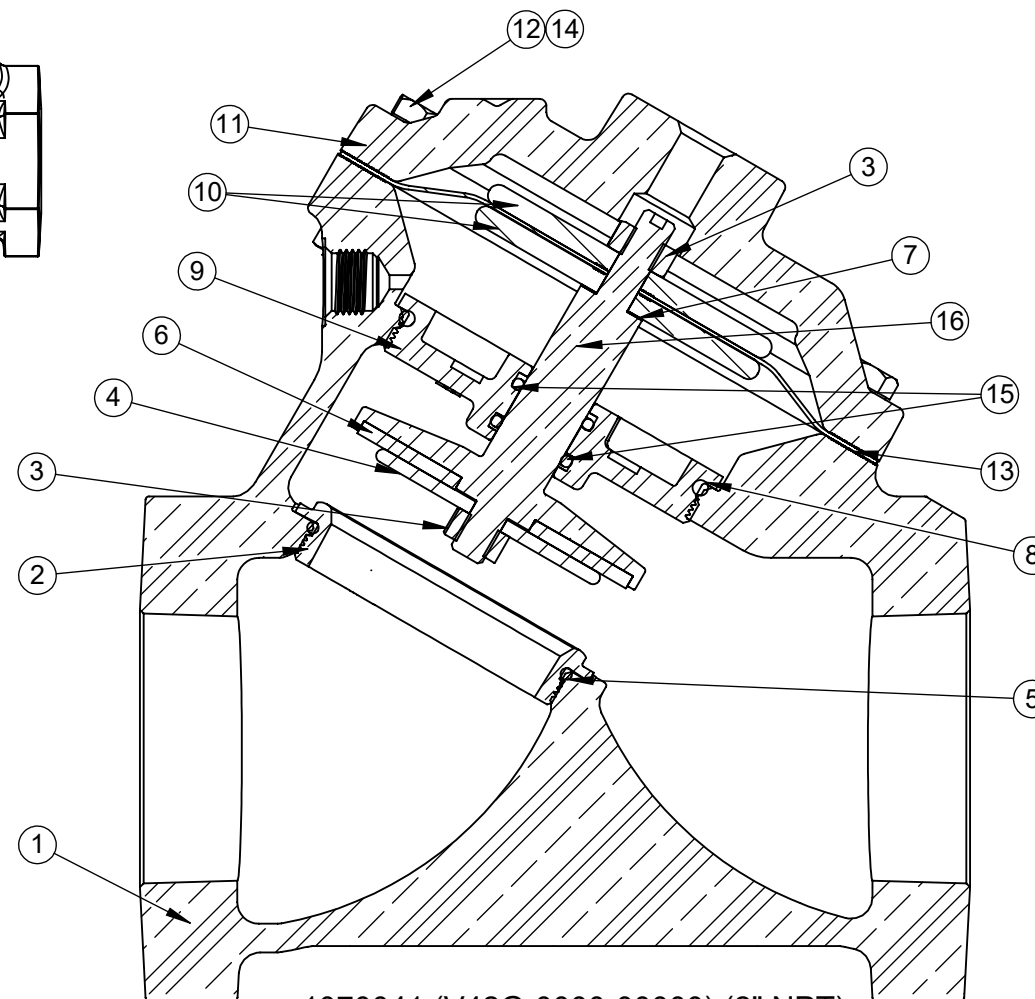
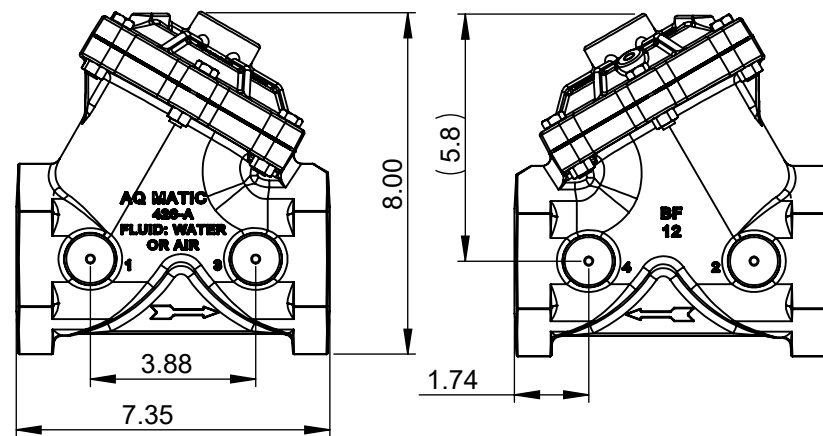

1070041 (V42G-0000-00000) (2" NPT)
 1070042 (V42H-0000-00000) (2 1/2" NPT)
NORMALLY OPEN (STANDARD)

APPLY LOCTITE 565 HERE

APPLY LOCTITE 565 HERE

DO NOT APPLY LOCTITE TO O-RINGS

NOTE:

- AMERICAN NATIONAL STANDARD TAPER PIPE THREADS (NPT) PER ANSI B2.1-1968.
- VALVES AVAILABLE WITH BSPT END CONNECTIONS.

THIS DOCUMENT IS SOLELY THE PROPERTY OF AQ-MATIC REPRODUCTION, USE DISCLOSURE, OR TRANSMISSION OF THIS DOCUMENT OR DETAILS CONTAINED HEREIN, IN PART OR IN WHOLE, IS PROHIBITED WITHOUT THE WRITTEN CONSENT OF AQ-MATIC ENGINEERING. THIS DOCUMENT AND ANY COPIES SHALL BE RETURNED TO AQ-MATIC UPON WRITTEN REQUEST.

DO NOT SCALE DRAWING. DIMS. ARE IN INCHES [mm]
 INTERPRET DIMS AND TOLERANCES PER ASME Y14.5M -1994 UNLESS OTHERWISE SPECIFIED:
 CORNER FILLETS R.005-.020 [.127- .508]
 TOLERANCES:
 ANGLES : ± 1°
 1 PLACE :XX: ± .015 [0.38]
 2 PLACE :XX: ± .01 [0.3]
 3 PLACE :XXX: ± .005 [0.13]

THE COMPONENT, PART, OR ASSEMBLY DESCRIBED IN THIS DOCUMENT MUST COMPLY WITH THE EU (EUROPEAN UNION) DIRECTIVE: RoHS DIRECTIVE 2011/65/EC.

THIRD ANGLE PROJECTION

APPROVALS DATE

DRAWN TRK 5/7/19

CHECKED BY

APPROVED



CATALOG SHEET, 426
 DIAPHRAGM VALVE STANDARD MODEL

B DWG NO. 1077616 REV. Y

SCALE SOLIDWORKS FORMAT SHEET 1 OF 1

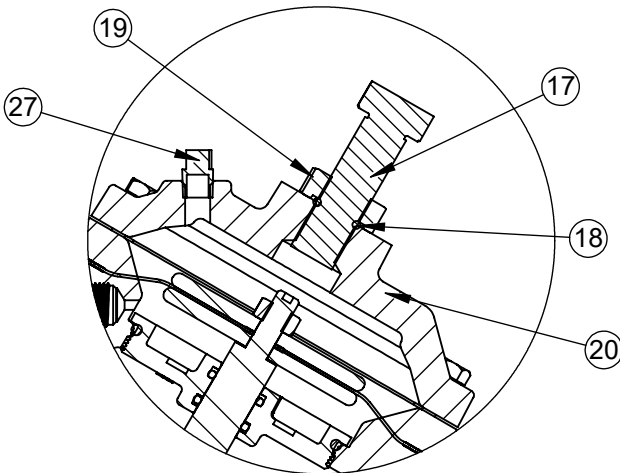

1072939 (V42G-0010-00000) (2"NPT)
1072998 (V42H-0010-00000) (2 1/2" NPT)
LIMIT STOP

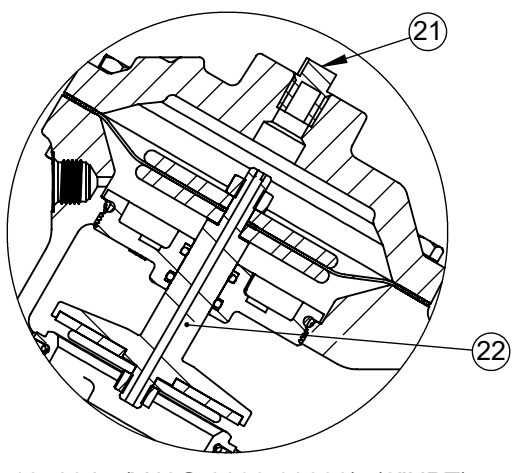

1072945 (V42G-0030-00000) (2"NPT)
1073002 (V42H-0030-00000) (2 1/2" NPT)
NORMALLY CLOSED

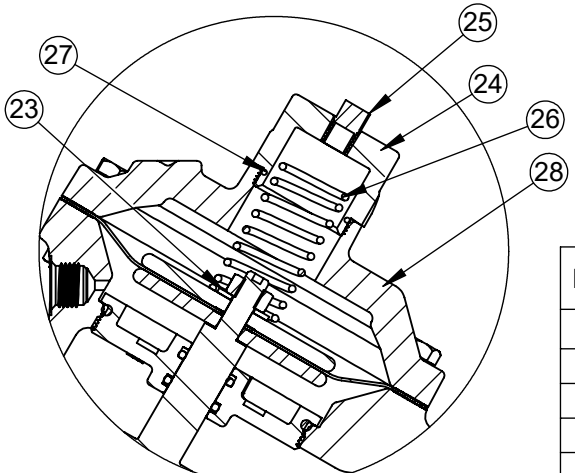

1072935 (V42G-0002-00000) (2"NPT)
1072996 (V42H-0002-00000) (2 1/2" NPT)
SPRING ASSIST CLOSED

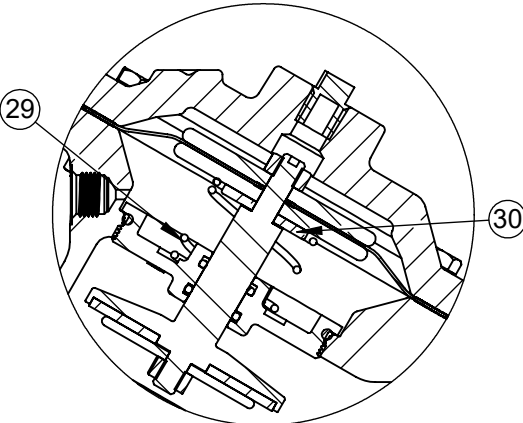

1072932 (V42G-0001-00000) (2"NPT)
1072994 (V42H-0001-00000) (2 1/2" NPT)
SPRING ASSIST OPEN

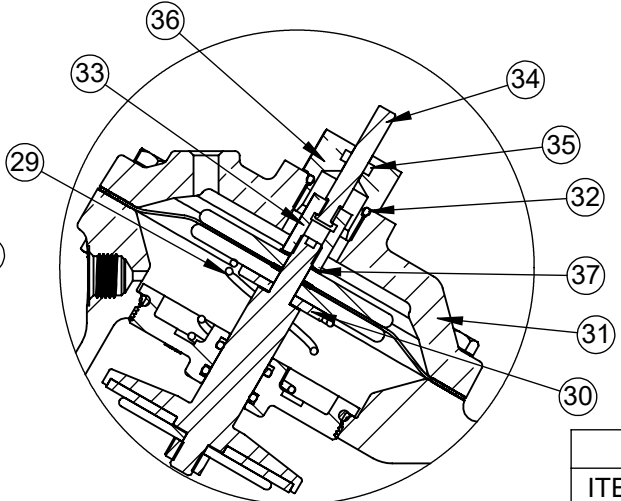

1072943 (V42G-0021-00000) (2"NPT)
1073001 (V42H-0021-00000) (2 1/2" NPT)
POSITION INDICATOR

SEE REVERSE SIDE FOR STANDARD NORMALLY OPEN MODEL

- NOTE:
1. SPRING ASSIST CLOSED MODEL CANNOT BE COMBINED WITH LIMIT STOP OR POSITION INDICATOR MODELS.
 2. VALVES AVAILABLE WITH B.S.P. OR J.I.S. END CONNECTIONS.

TORQUE TABLE		
ITEM#	DESCRIPTION	TORQUED TO (+/- 10%)
19	NUT	120 IN/LBS
24	RETAINER NUT	140 IN/LBS
33	SHAFT GUIDE BUSHING	140 IN/LBS
36	TOP NUT	120 IN/LBS

REVISIONS				
ECN	REV.	DESCRIPTION	DATE	APP'D
		SEE PAGE #1 FOR REVISION DETAILS		

NO.	DESCRIPTION	STD	PART NO.	QTY
LIMIT STOP MODEL				
17	SCREW	*	1078676 (SCS-0042)	1
18	O-RING	*	1071690 (ORB-112)	1
19	NUT	*	1074434 (426-U)	1
20	CAP	CAST IRON	1074354 (426-CCC)	1
		BRASS	1074357 (426-CCCB)	
NORMALLY CLOSED MODEL				
21	PIPE PLUG (1/4" NPT)	PLATED STEEL	1071918 (PLZ-0008)	1
		BRASS	1071904 (PLB-0009)	
22	COMBINATION SHAFT (NORMALLY CLOSED)	*	44021-01 (426-LL)	1
SPRING ASSIST CLOSED MODEL				
23	CENTERING WASHER	BRASS	1074083 (421-AH)	1
24	RETAINER NUT	SS	1074433 (426-TIS)	1
25	PIPE PLUG (1/8" NPT)	PLATED STEEL	1071917 (PLZ-0005)	1
		BRASS	1071903 (PLB-0007)	
26	SPRING	*	1078688 (426-SS)	1
27	O-RING	*	1071677 (ORB-025)	1
28	CAP	CAST IRON	1074352 (426-CC)	1
		CAST BRASS	1074353 (426-CCB)	
SPRING ASSIST OPEN MODEL				
29	SPRING		1078692 (426-S)	1
30	CENTERING WASHER	BRASS	1074436	1
POSITION INDICATOR MODEL				
31	CAP	CAST IRON	1074360 (426-CF)	1
		CAST BRASS	1074364 (426-CFB)	
32	O-RING	*	1071692 (ORB-116)	1
33	SHAFT GUIDE BUSHING	*	1074121 (421-GF)	1
34	INDICATOR SHAFT	*	1074325 (425-PM)	1
35	O-RING	*	1071688 (ORB-108TC)	1
36	TOP NUT	*	1074332 (425-TB)	1
37	LOCKWASHER	*	1073590 (WAS-0007)	1

REPAIR PARTS KITS	
DESCRIPTION	PART NO.
INT. PARTS KIT (LIMIT STOP) CONSISTS OF STANDARD ITEM NO'S 17, 18, 19	1074405 (426-LS)
INT. PARTS KIT (NORM. CLOSED) CONSISTS OF STANDARD ITEM NO'S 4, 9,10 (2), 22	1070132 (426-RG)
INT. PARTS KIT (SPRING ASSIST CLOSED) CONSISTS OF STANDARD ITEM NO'S 23,26,27	1074425 (426-SC)
INT. PARTS KIT (SPRING ASSIST OPEN) CONSISTS OF STANDARD ITEM NO'S 7, 29, 30	1074427 (426-SO)
INT. PARTS KIT (POSITION INDICATOR) CONSISTS OF STD ITEM NO'S 32 THRU 37	1074413 (426-PI)
CONVERSION KITS	
DESCRIPTION	PART NO.
CONVERSION KIT (LIMIT STOP) CONSISTS OF STANDARD ITEM NO'S 17, 18, 19, 20	1074406 (426-LSC)
CONVERSION KIT (SPRING ASSIST CLOSED) CONSISTS OF STANDARD ITEM NO'S 23 THRU 28	1074426 (426-SCC)
CONVERSION KIT (SPRING ASSIST OPEN) CONSISTS OF STANDARD ITEM NO'S 7, 29, 30	1074427 (426-SO)
CONVERSION KIT (POSITION INDICATOR) CONSISTS OF STANDARD ITEM NO'S 31 THRU 37	1074414 (426-PIC)

THIS DOCUMENT IS SOLELY THE PROPERTY OF AQ-MATIC REPRODUCTION, USE DISCLOSURE, OR TRANSMISSION OF THIS DOCUMENT OR DETAILS CONTAINED HEREIN, IN PART OR IN WHOLE, IS PROHIBITED WITHOUT THE WRITTEN CONSENT OF AQ-MATIC ENGINEERING. THIS DOCUMENT AND ANY COPIES SHALL BE RETURNED TO AQ-MATIC UPON WRITTEN REQUEST.

DO NOT SCALE DRAWING. DIMS. ARE IN INCHES [mm] INTERPRET DIMS AND TOLERANCES PER ASME Y14.5M -1994 UNLESS OTHERWISE SPECIFIED: CORNER FILLETS R.005-.020 [0.127-.508] TOLERANCES: ANGLES: ±.1° 1 PLACE .XX: ±.015 [0.38] 2 PLACE .XX: ±.01 [0.3] 3 PLACE .XXX: ±.005 [0.13]

THE COMPONENT, PART, OR ASSEMBLY DESCRIBED IN THIS DOCUMENT MUST COMPLY WITH THE EU (EUROPEAN UNION) DIRECTIVE: RoHS DIRECTIVE 2011/65/EC.

THIRD ANGLE PROJECTION

APPROVALS: DATE: 5/7/19

DRAWN: TRK

CHECKED BY:

APPROVED:

CATALOG SHEET, 426
DIAPHRAGM VALVE STANDARD MODEL

B DWG NO. 1077616 REV. Y

SCALE SOLIDWORKS FORMAT SHEET 1 OF 1