

ASSEMBLY TOOLS	
DESCRIPTION	PART NO.
FOR INSTALLATION & REMOVAL OF SHAFT (ITEM #5) (TOOL NOT SHOWN)	1077837
FOR INSTALLATION & REMOVAL OF UPPER DIAPHRAGM PLATE (ITEM #12) (TOOL NOT SHOWN)	1075224 (526-Z)

TORQUE TABLE		
ITEM #	DESCRIPTION	TORQUED TO (+/- 10%)
2	PLATE, DISC	22.5 IN-LB
12	UPR. DIA. PLATE	40 IN-LB
15 & 16	CA P SCREW & NUT	32.5 IN-LB

REVISIONS				
ECN	REV.	DESCRIPTION	DATE	APP'D
100401	L	1- WAS: 1075174,-NOW:43051 2-REM'D:1075172 NORYL SHAFT	03/30/12	TJM
101856	M	1-WAS 1071746- NOW: 1010140	03/19/13	TJM
103884	N	ITEM # 31- WAS 1074970, 2- UPDATED TITLE BLOCK	10/16/14	TJM
1001	O	AQ TEMPLATE UPDATE & VERIFIED PART NUMBERS	01/17/17	MGs
1507	P	REMOVE BR FROM DRW NUMBER, CORRECT MINOR ERRORS, ADD TORQUE TABLE	05/14/19	KJB
1964	Q	CATALOG SHEET UPDATE WITH MODEL NUMBERS	11/1/21	TRK
2287	R	CATALOG SHEET UPDATE, ELIMINATE O-RING 1071713	3/11/24	TRK

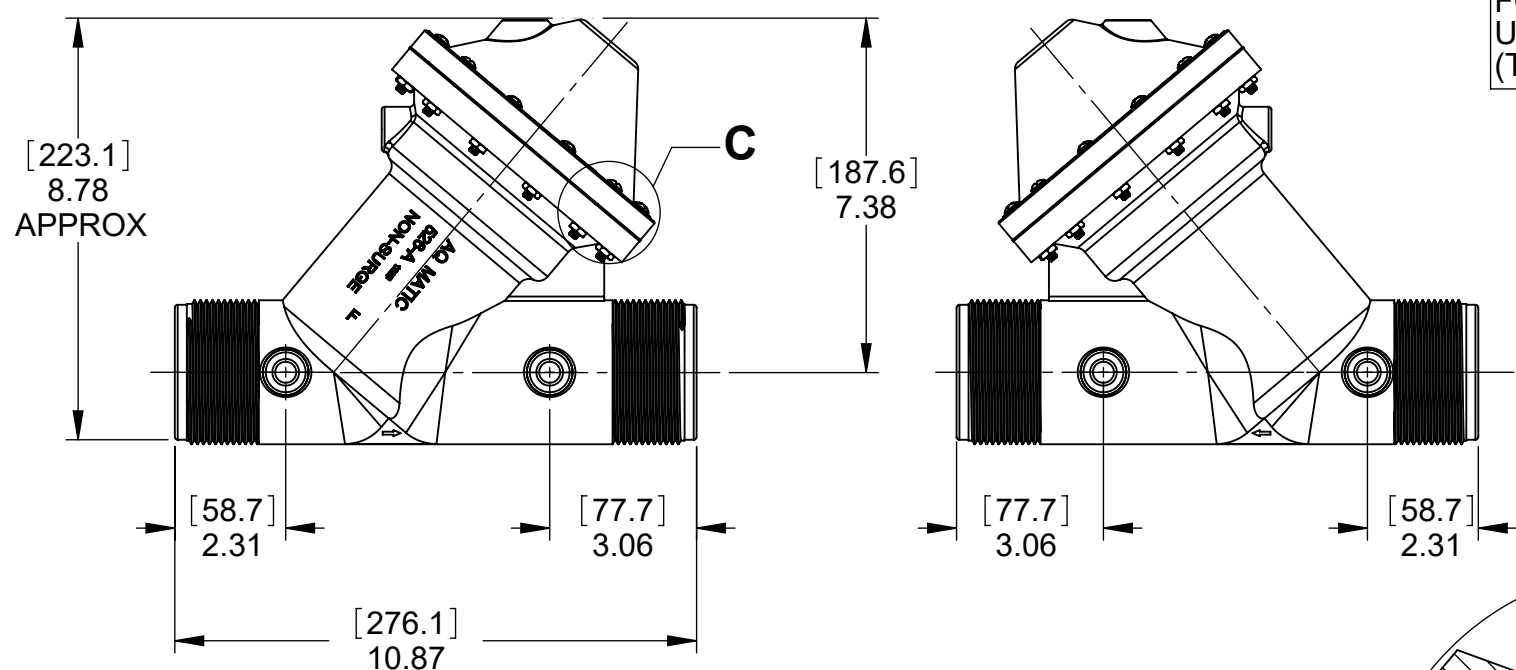

DISC NUT/SHAFT TO BE FLUSH AFTER COMPONENTS ARE TIGHTENED TO 20-25 IN-LB [2.3-2.8 Nm]

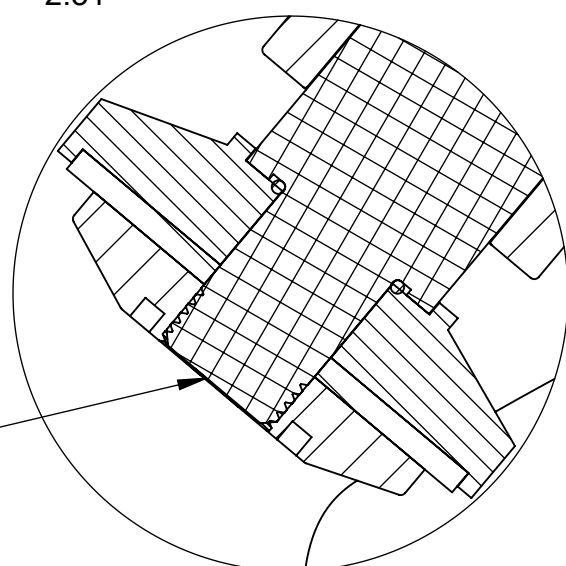

DETAIL B

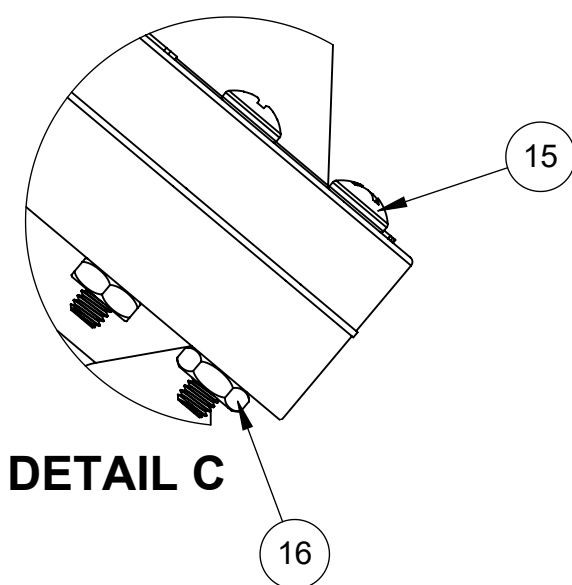

DETAIL C

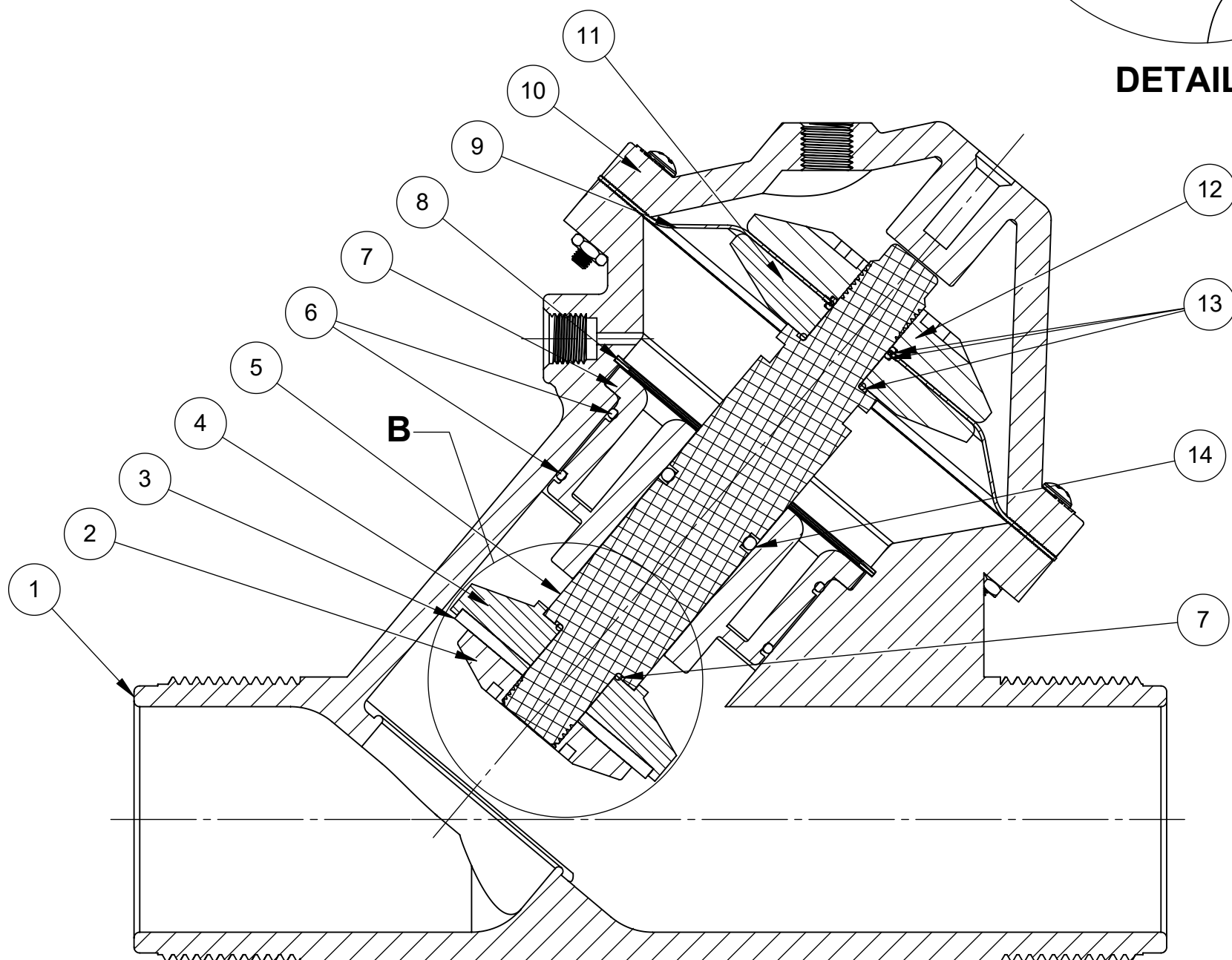

NORMALLY OPEN MODEL				
ITEM NO.	DESCRIPTION		PART NUMBER	QTY.
1	BODY, 526	NORYL	1075162 (526-AK)	1
2	DISC PLATE, 526	NORYL	1075176 (526-EK)	1
3	DISC	EPDM	1075181 (526-J)	1
		BUTYL	1075182 (526-JJ)	
		FKM	1075183 (526-JV)	
4	DISC HOLDER	PVC	1075197 (526-RP)	1
5	SHAFT	PVC	43119	1
6	O-RING, 2-148	EPDM	1071738 (ORE-148)	2
		BUTYL	1071773 (ORJ-148)	
		FKM	1071810 (ORV-148)	
7	SHAFT GUIDE	NORYL	1075178	1
8	RETAINING RING	SS	1075180	1
9	DIAPHRAGM	BUNA	1075177 (526-FB)	1
10	CAP, 526	NORYL	1075167 (526-BBOK)	1
11	LWR. DIAP. PLATE	NORYL	43051	1
12	UPR. DIAP. PLATE	NORYL	43050	1
13	O-RING, 2-018	EPDM	1071673 (ORE-018)	4
		BUTYL	1071762 (ORJ-018)	
		FKM	1071790 (ORV-018)	
14	O-RING, 2-214	EPDM	1010140 (ORE-214)	1
		BUTYL	1071778 (ORJ-214)	
		FKM	107817 (ORV-214)	
15	SCREW, 10-32 X 1 3/8", PHILLIPS	SS	1072382 (SCS-0098)	12
16	HEX NUT, 10-32	SS	1071648 (NUS-0006)	12

REPAIR PARTS KITS		
DIAPHRAGM & SEALS KIT	1070275 (526-RA) EPDM KIT INCLUDES DIAPHRAGM 1075177 (526-FB)	1070283 (526-RAJ) BUTYL KIT INCLUDES DIAPHRAGM 1075177 (526-FB)
CONSISTS OF ITEM NO'S 3,6(2),9,13(4),14	1070291 (526-RAV) FKM KIT INCLUDES DIAPHRAGM 1075177 (526-FB)	
INTERNAL PARTS KIT (NORMALLY OPEN) CONSISTS OF ITEM NO'S 2,4,5,7,11,12	1070299 (K526-RF)	

- SEE DRAWING 1081309 FOR THREADED SOCKET WELD ENDS AND THREADED FLANGED ADAPTORS
- SEE SHEET 2 FOR CONFIGURATION OPTIONS

1070180 (K526-X200-14000)  
**NORMALLY OPEN (STANDARD)**

THIS DOCUMENT IS SOLELY THE PROPERTY OF AQ-MATIC REPRODUCTION, USE DISCLOSURE, OR TRANSMISSION OF THIS DOCUMENT OR DETAILS CONTAINED HEREIN, IN PART OR IN WHOLE, IS PROHIBITED WITHOUT THE WRITTEN CONSENT OF AQ-MATIC ENGINEERING. THIS DOCUMENT AND ANY COPIES SHALL BE RETURNED TO AQ-MATIC UPON WRITTEN REQUEST.

DO NOT SCALE DRAWING. DIMS. ARE IN INCHES [mm] UNLESS OTHERWISE SPECIFIED:  
\*CORNER FILLETS R.005-.020 [0.127-.508]  
TOLERANCES:  
ANGLES: ± 1°  
1 PLACE .X: ± .100 [2.54]  
2 PLACE .XX: ± .010 [0.25]  
3 PLACE .XXX: ± .005 [0.13]

THE COMPONENT, PART, OR ASSEMBLY DESCRIBED IN THIS DOCUMENT MUST COMPLY WITH THE EU (EUROPEAN UNION) DIRECTIVE: RoHS DIRECTIVE 2011/65/EC.

THIRD ANGLE PROJECTION	
APPROVALS	DATE
DRAWN TRK	3/25/21
CHECKED BY	
APPROVED	



CATALOG SHEET, 526  
DIAPHRAGM VALVE

SIZE <b>C</b>	DWG NO. <b>1077656</b>	REV. <b>R</b>
SCALE 1:1	SOLIDWORKS FORMAT	SHEET 1 OF 2

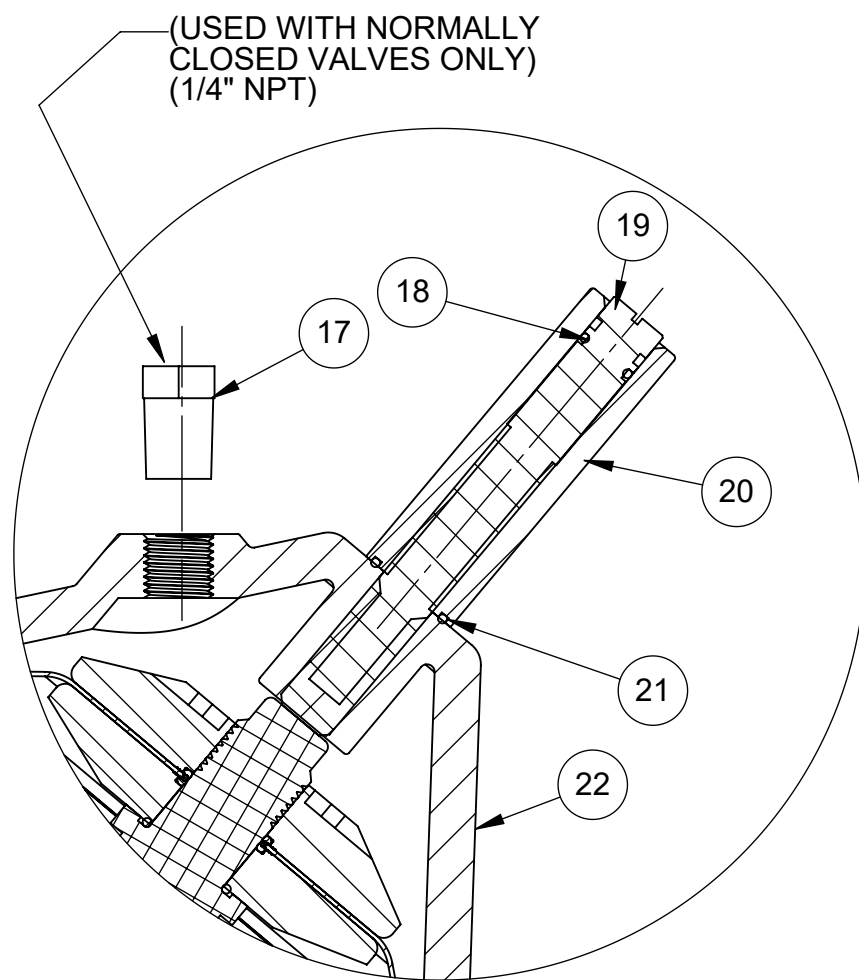

1070181 (K526-X210-14000)  
**LIMIT STOP**

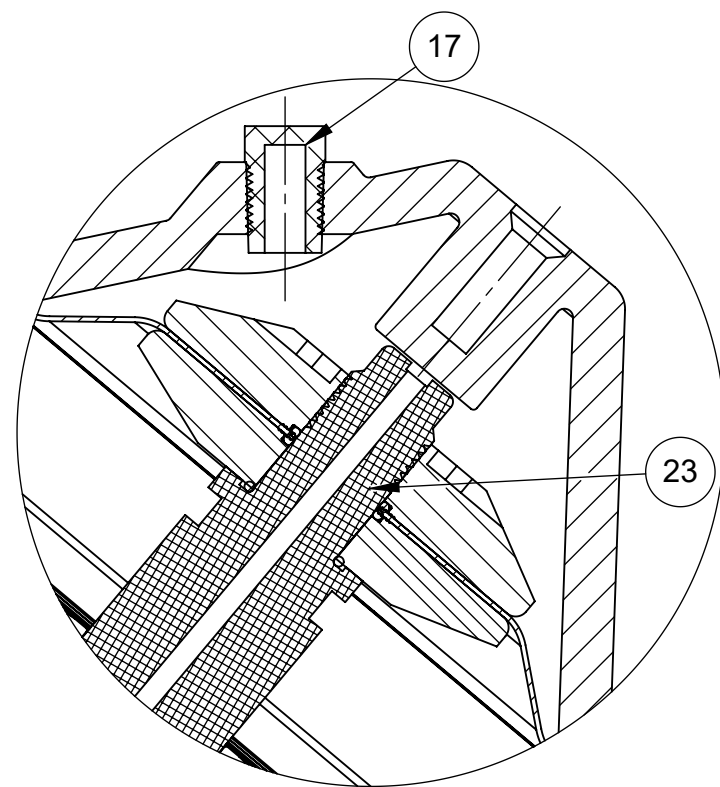

1071256 (K526-X230-14000)  
**NORMALLY CLOSED**

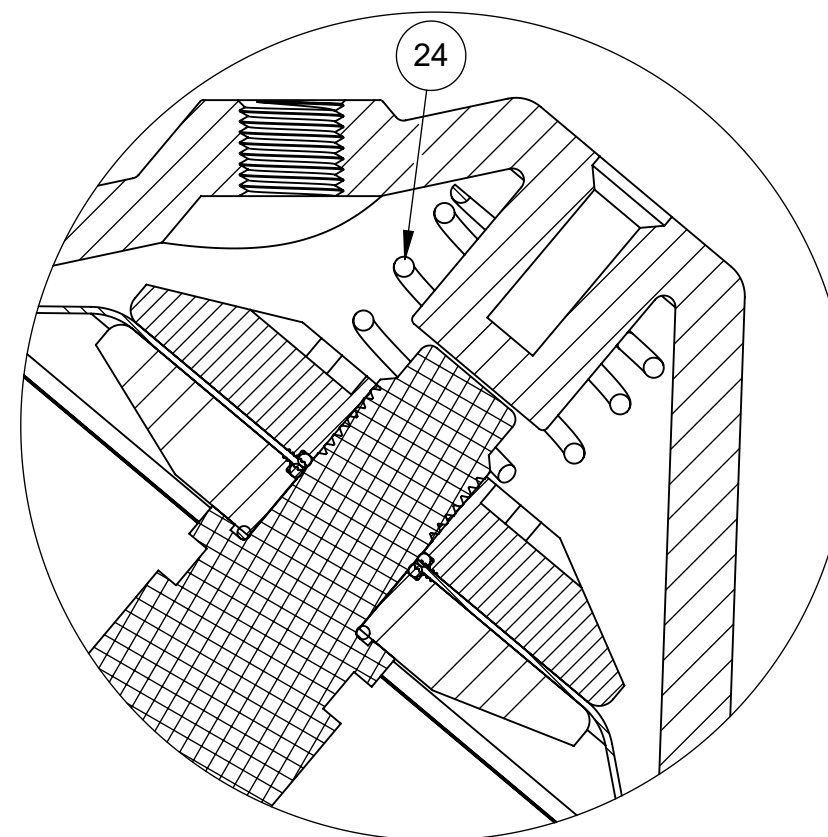

1071246 (K526-X202-14000)  
**SPRING ASSIST CLOSED**

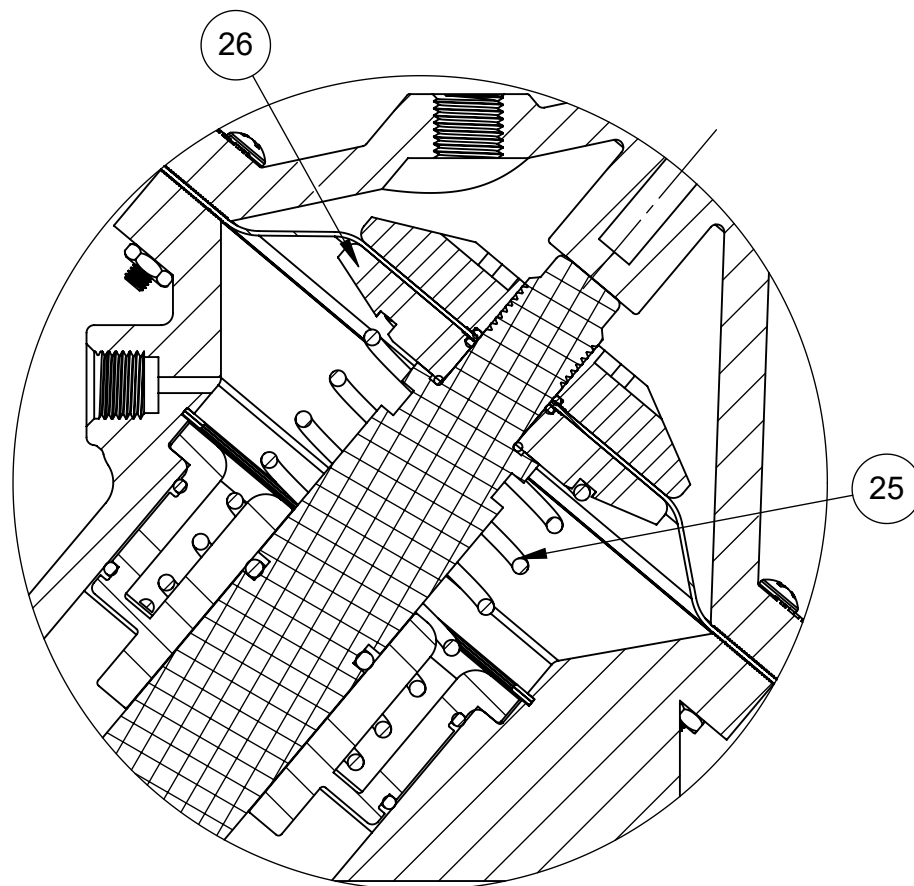

1071242 (K526-X201-14000)  
**SPRING ASSIST OPEN**

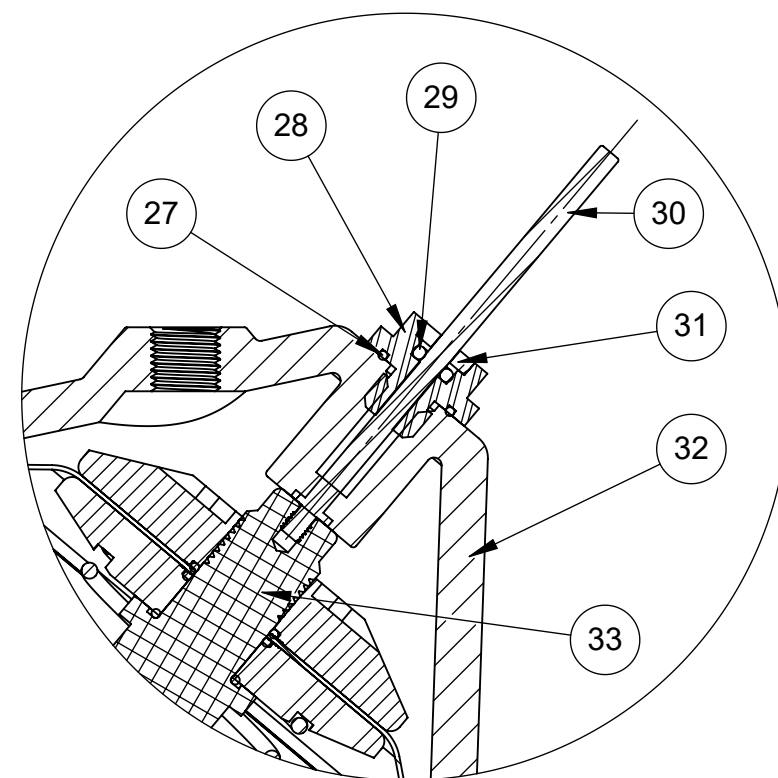

1071255 (K526-X221-14000)  
**POSITION INDICATOR**

- SEE DRAWING 1081309 FOR THREADED SOCKET WELD ENDS AND THREADED FLANGED ADAPTORS
- SEE SHEET 1 FOR STANDARD NORMALLY OPEN MODEL

REVISIONS				
ECN	REV.	DESCRIPTION	DATE	APP'D
		SEE SHEET 1 FOR LIST OF CHANGES		

LIMIT STOP MODEL				
ITEM NO.	DESCRIPTION		PART NUMBER	QTY.
17	MALE PIPE PLUG 1/4"	HDPE	1071913 (PLP-0010)	1
18	O-RING, 2-012	BUNA	1071668 (ORB-012)	1
19	LIMIT STOP SCREW	SS	1075223	1
20	LIMIT STOP NUT	SS	1075222	1
21	O-RING, 2-016	BUNA	1071671 (ORB-016)	1
22	CAP, 526	NORYL	1075167 (526-BBOK)	1

NORMALLY CLOSED MODEL				
ITEM NO.	DESCRIPTION		PART NUMBER	QTY.
17	MALE PIPE PLUG 1/4"	HDPE	1071913 (PLP-0010)	1
23	SHAFT, VALVE 526,NC	PVC	43143	1

SPRING ASSIST CLOSED				
ITEM NO.	DESCRIPTION		PART NUMBER	QTY.
24	SPRING, COMPRESSION	SS	1075202 (K526-T)	1

SPRING ASSIST OPEN MODEL				
ITEM NO.	DESCRIPTION		PART NUMBER	QTY.
25	SPRING, COMPRESSION		1267399 (526-SS)	1
26	DIAPHRAGM PLATE, LOWER, 526, SAO		1075175	1

POSITION INDICATOR MODEL				
ITEM NO.	DESCRIPTION		PART NUMBER	QTY.
27	O-RING, 2-016		1071671 (ORB-016)	1
28	GUIDE HOUSING, 521		1075038	1
29	O-RING, 2-106		1071687	1
30	ROD, PI, 526		1075184 (526-KD)	1
31	PLUG, GUIDE HOUSING, 520		1074971	1
32	CAP, 526		1075167 (526-BBOK)	1
33	SHAFT, VALVE 526, PI		43142	1

NOTES:

1. POSITION INDICATOR MODEL CANNOT BE COMBINED WITH NORMALLY CLOSED OR LIMIT STOP OPTIONS.
2. POSITION INDICATOR MODEL FURNISHED WITH SPRING ASSIST OPEN OPTION.

CONVERSION KITS	
DESCRIPTION	PART NO.
CONVERSION KIT (LIMIT STOP) CONSISTS OF ITEM NO'S 18 THRU 22	1071225 (526-LSC)
CONVERSION KIT (SPRING ASSIST CLOSED) CONSISTS OF ITEM NO 24	1075200 (526-SC)
CONVERSION KIT (SPRING ASSIST OPEN) CONSISTS OF ITEM NO'S 25 & 26	1071227 (526-SO)
CONVERSION KIT (POSITION INDICATOR) CONSISTS OF ITEM NO'S 27 THRU 33	1079674 (K526-PI-C)

REPAIR PARTS KITS	
DESCRIPTION	PART NO.
INT. PARTS KIT (LIMIT STOP) CONSISTS OF NO'S 18 THRU 21	1075191 (526-LS)
INT. PARTS KIT (NORM. CLOSED) CONSISTS OF ITEM NO'S 3,4,7,11,12, 23	1071226 (K526-RG)
INT. PARTS KIT (SPRING ASSIST CLOSED) CONSISTS OF ITEM NO. 24	1075200 (526-SC)
INT. PARTS KIT (SPRING ASSIST OPEN) CONSISTS OF ITEM NO'S 25 & 26	1071227 (526-SO)
INT. PARTS KIT (POSITION INDICATOR) CONSISTS OF ITEM NO'S 27 THRU 31, 33	1081804 (526-PI)

THIS DOCUMENT IS SOLELY THE PROPERTY OF AQ-MATIC REPRODUCTION, USE DISCLOSURE, OR TRANSMISSION OF THIS DOCUMENT OR DETAILS CONTAINED HEREIN, IN PART OR IN WHOLE, IS PROHIBITED WITHOUT THE WRITTEN CONSENT OF AQ-MATIC ENGINEERING. THIS DOCUMENT AND ANY COPIES SHALL BE RETURNED TO AQ-MATIC UPON WRITTEN REQUEST.

DO NOT SCALE DRAWING. DIMS. ARE IN INCHES [mm] INTERPRET DIMS AND TOLERANCES PER ASME Y14.5M -1994 UNLESS OTHERWISE SPECIFIED:  
CORNER FILLETS R.005-.020 [0.127-.508]  
TOLERANCES:  
ANGLES: ± 1°  
1 PLACE .X: ± .100 [2.54]  
2 PLACE .XX: ± .010 [0.25]  
3 PLACE .XXX: ± .005 [0.13]

THE COMPONENT, PART, OR ASSEMBLY DESCRIBED IN THIS DOCUMENT MUST COMPLY WITH THE EU (EUROPEAN UNION) DIRECTIVE: RoHS DIRECTIVE 2011/65/EC.

THIRD ANGLE PROJECTION

APPROVALS: DATE: 3/25/21

DRAWN: TRK  
CHECKED BY:  
APPROVED:

**AQ Matic**

CATALOG SHEET, SERIES 526 DIAPHRAGM VALVE

SIZE: C DWG NO.: 1077656 REV.: R  
SCALE: 1:1 SOLIDWORKS FORMAT SHEET 2 OF 2