

REPAIR PARTS KITS

DESCRIPTION	PART NO.	
DIAPHRAGM & SEALS KIT CONSIST OF ITEM NO'S 5(2), 7, 8, 9, 10, 14, 16, 17	1070108 (AV5-RA)	1070503 (AV5-RAHT)
	INCLUDES DISC 1074310 (425-JH) DIAPHRAGM 1074296 (425-FB)	INCLUDES DISC 1074311 (425-JT) DIAPHRAGM 1074297 (425-FV)
INT. PARTS KIT (NORM. OPEN) CONSIST OF STANDARD ITEM NO'S 3, 4, 6, 15, 18	1070504 (AV5-RF)	
SEAT (ITEM NO. 13)	1074321 (425-MO)	

ASSEMBLY TOOLS

DESCRIPTION	PART NO.
FOR INSTALLATION & REMOVAL OF SEAT (ITEM #13) (TOOL NOT SHOWN)	1074411 (426-MT)
FOR INSTALLATION & REMOVAL OF SHAFT GUIDE (ITEM #3) (TOOL NOT SHOWN)	1074299 (425-GAT)

- NOTE:
1. AMERICAN NATIONAL STANDARD TAPER PIPE THREADS (NPT) PER ANSI B2.1-1968
 2. VALVES AVAILABLE WITH B.S.P.T. END CONNECTIONS.

*1074299 - SPANNER WRENCH TOOL USED ON SHAFT GUIDES MADE BETWEEN 2014 THRU 2018. ALL OTHERS ARE SOCKET STYLE

TORQUE TABLE		
ITEM #	DESCRIPTION	TORQUED TO(+/- 10%)
13	SEAT	120 IN/LBS
5	UPPER NUT	140 IN/LBS
5	LOWER NUT	140 IN/LBS
3	SHAFT GUIDE	120 IN/LBS
11 & 12	NUT, HEX SCREW	140 IN/LBS

REVISIONS				
ECN	REV.	DESCRIPTION	DATE	APP'D
1824	N	CATALOG SHEET UPDATE, PART CHANGES	1/22/21	TRK
2219	P	CATALOG SHEET UPDATE, PART CHANGES	3/31/23	TRK

NORMALLY OPEN VALVE				
ITEM NO.	DESCRIPTION	STD.	PART NUMBER	QTY.
1	MACHINE VALVE BODY, 425	CAST IRON	1074277 (425-A)	1
	MACHINE VALVE BODY, 425, BSP		1074278 (425-A-BSP)	
2	CAP, 425, NPT	CAST IRON	* 1074281 (425-C)	1
3	SHAFT GUIDE (ASSY TOOL REQUIRED)	STAINLESS STEEL	* 43848	1
4	COMBO SHAFT, NORMALLY OPEN	STAINLESS STEEL	* 44017 (425-L)	1
5	HEX NUT (5/16"-24)	STAINLESS STEEL	* 1263853 (RMET)	2
6	DISC PLATE	STAINLESS STEEL	* 43943	1
7	DISC, 425	HYCAR	* 1074310 (425-JH)	1
8	O-RING 2-038	FKM	* 1071795 (ORB-038)	1
9	O-RING 2-035	FKM	* 1071794 (ORV-035)	1
10	O-RING 2-206	AFLAS	* 1071664 (ORA-206)	2
11	HEX SCREW 5/16"-18	PLATED STEEL	* 1072400 (SCZ-0013)	6
12	HEX NUT 5/16"-18	PLATED STEEL	* 1071657 (NUZ-0011)	6
13	SEAT (ASSY TOOL REQUIRED)	BRASS	* 1074321 (425-MO)	1
14	DIAPHRAGM	BUNA-N	* 1074296 (425-FB)	1
		FKM	1074297 (425-FV)	
15	PLATE, LOWER DIAPHRAGM	STAINLESS STEEL	* 1074295 (425-DAA)	1
16	O-RING, 2-011	FKM	* 1071786 (ORV-011)	1
17	LOCKWASHER, 5/16, INTERNAL	STAINLESS STEEL	* 1073590 (WAS-0007)	1
18	PLATE, UPPER DIAPHRAGM	STAINLESS STEEL	* 1074294 (425-DA)	1

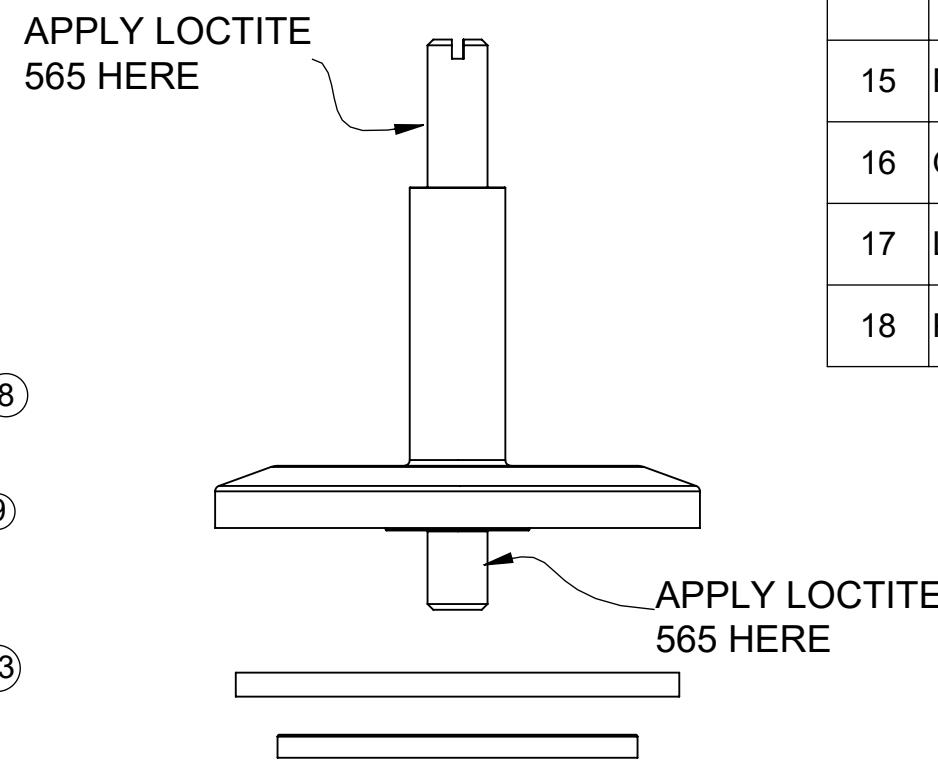
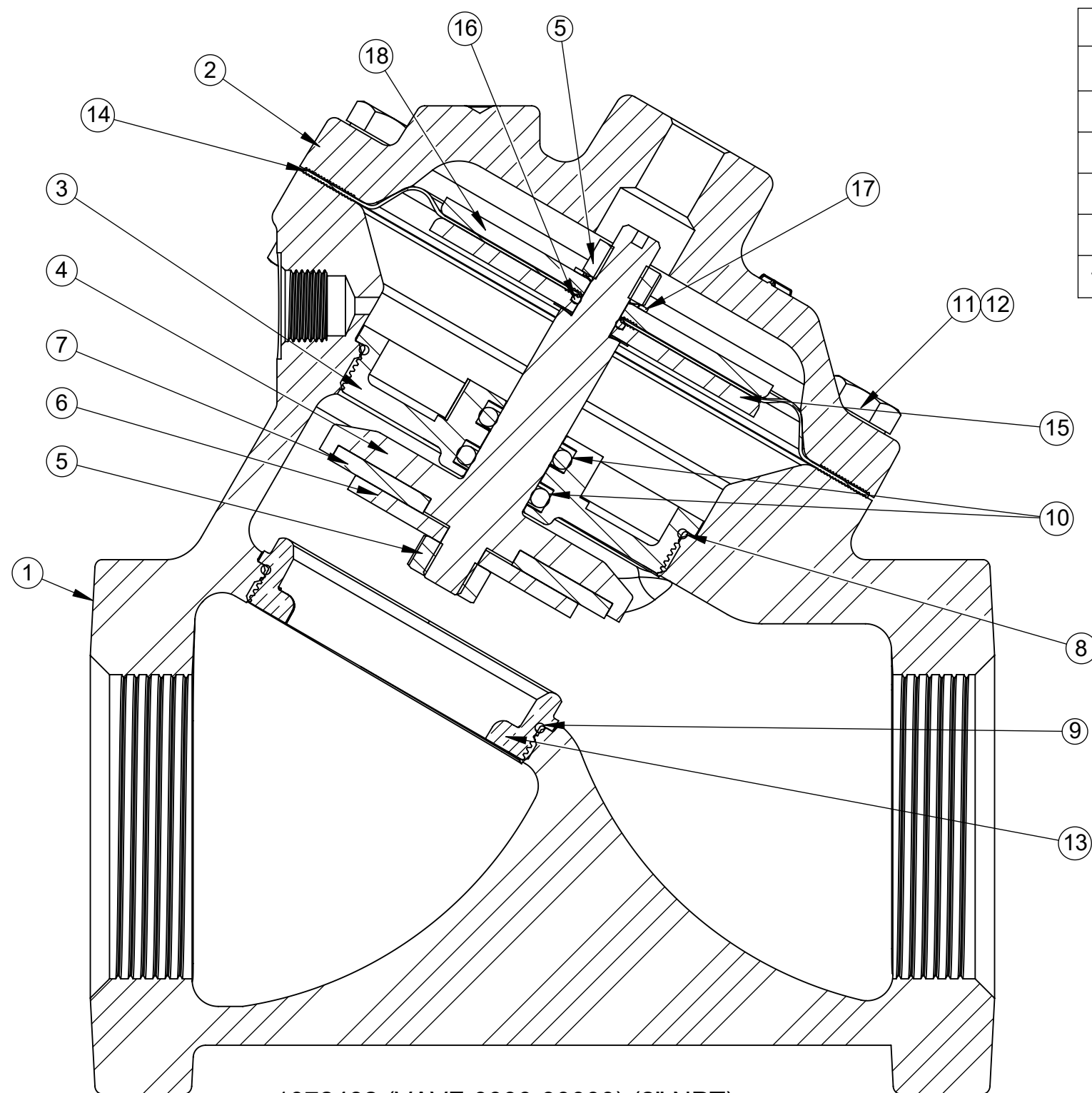
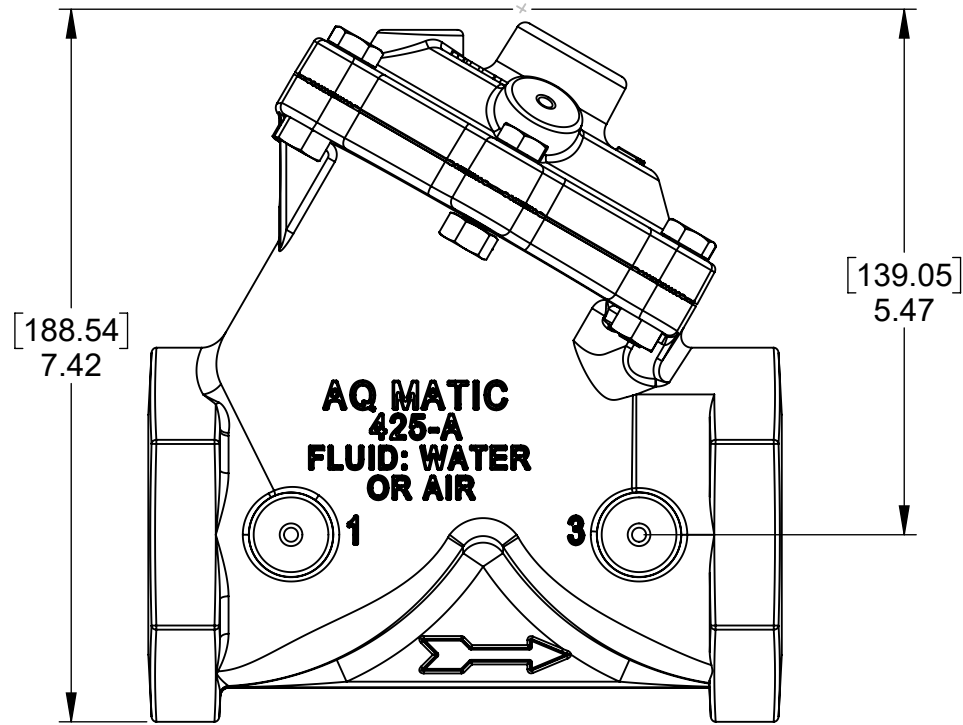

DO NOT APPLY LOCTITE TO O-RINGS

- NOTE:
1. AMERICAN NATIONAL STANDARD TAPER PIPE THREADS (NPT) PER ANSI B2.1-1968.
 2. VALVES AVAILABLE WITH B.S.P.T. END CONNECTIONS.

1072482 (VAVF-0000-90000) (2" NPT)
NORMALLY OPEN (STANDARD)

THIS DOCUMENT IS SOLELY THE PROPERTY OF AQ-MATIC REPRODUCTION, USE DISCLOSURE, OR TRANSMISSION OF THIS DOCUMENT OR DETAILS CONTAINED HEREIN, IN PART OR IN WHOLE, IS PROHIBITED WITHOUT THE WRITTEN CONSENT OF AQ-MATIC ENGINEERING. THIS DOCUMENT AND ANY COPIES SHALL BE RETURNED TO AQ-MATIC UPON WRITTEN REQUEST.

INTERPRET DIMENSIONS AND TOLERANCES PER ASME Y14.5M -1994

UNLESS OTHERWISE SPECIFIED:
DIMENSIONS ARE IN INCHES (mm)
CORNER FILLETS R.005-020 [127-508]
TOLERANCES:
ANGLES : ± 1°
1 PLACE .X: ± .100 [2.54]
2 PLACE .XX: ± .010 [0.25]
3 PLACE .XXX: ± .005 [0.13]

THE COMPONENT OR PRODUCT DESCRIBED IN THIS DOCUMENT MUST COMPLY WITH RoHS 3 EU (EUROPEAN UNION) DIRECTIVE 2015/863

THIRD ANGLE PROJECTION

APPROVALS: TRK DATE: 1/22/21

DESCRIPTION: CATALOG SHEET, VAV5

SIZE: C DWG NO.: 1077637 REV.: P

SCALE: 1:2 SOLIDWORKS FORMAT SHEET 1 OF 2

REVISIONS				
ECN	REV.	DESCRIPTION	DATE	APP'D
1824	N	CATALOG SHEET UPDATE, PART CHANGES	1/22/21	TRK
2219	P	CATALOG SHEET UPDATE, PART CHANGES	3/31/23	TRK

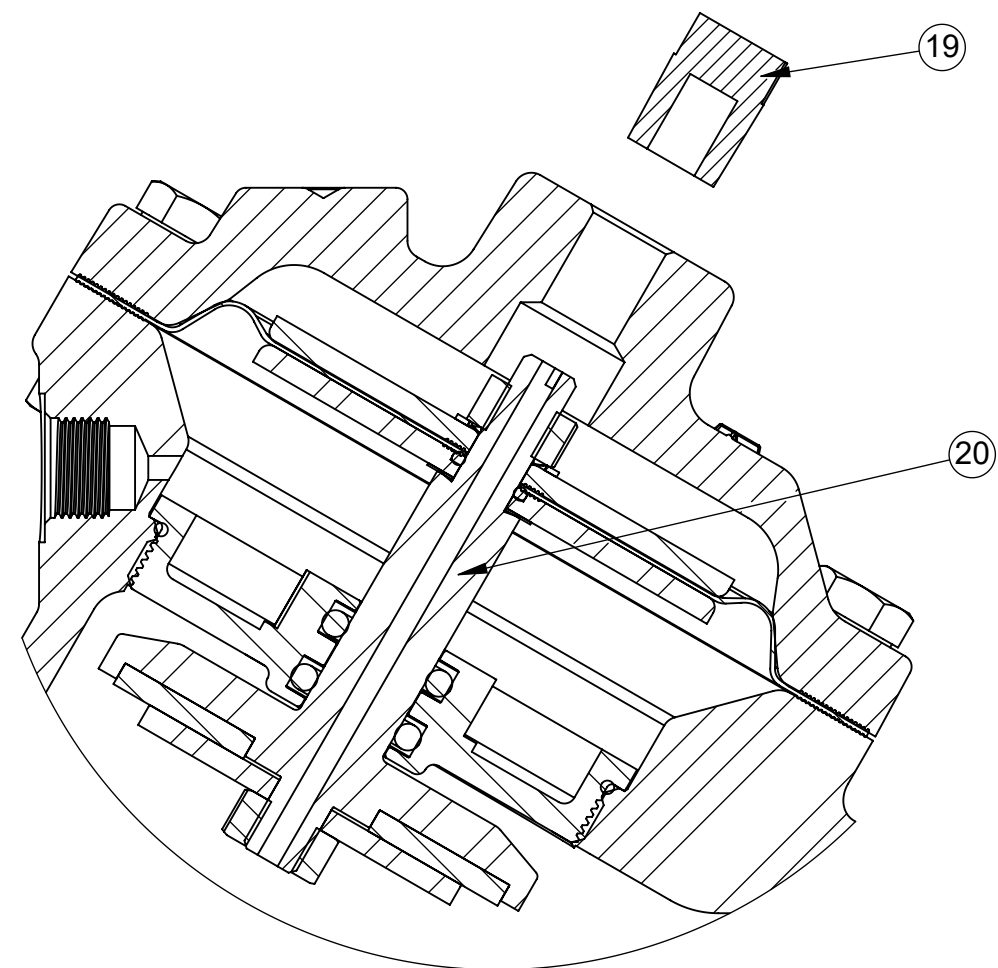

1072486 (VAVF-0030-90000) (2" NPT)
NORMALLY CLOSED

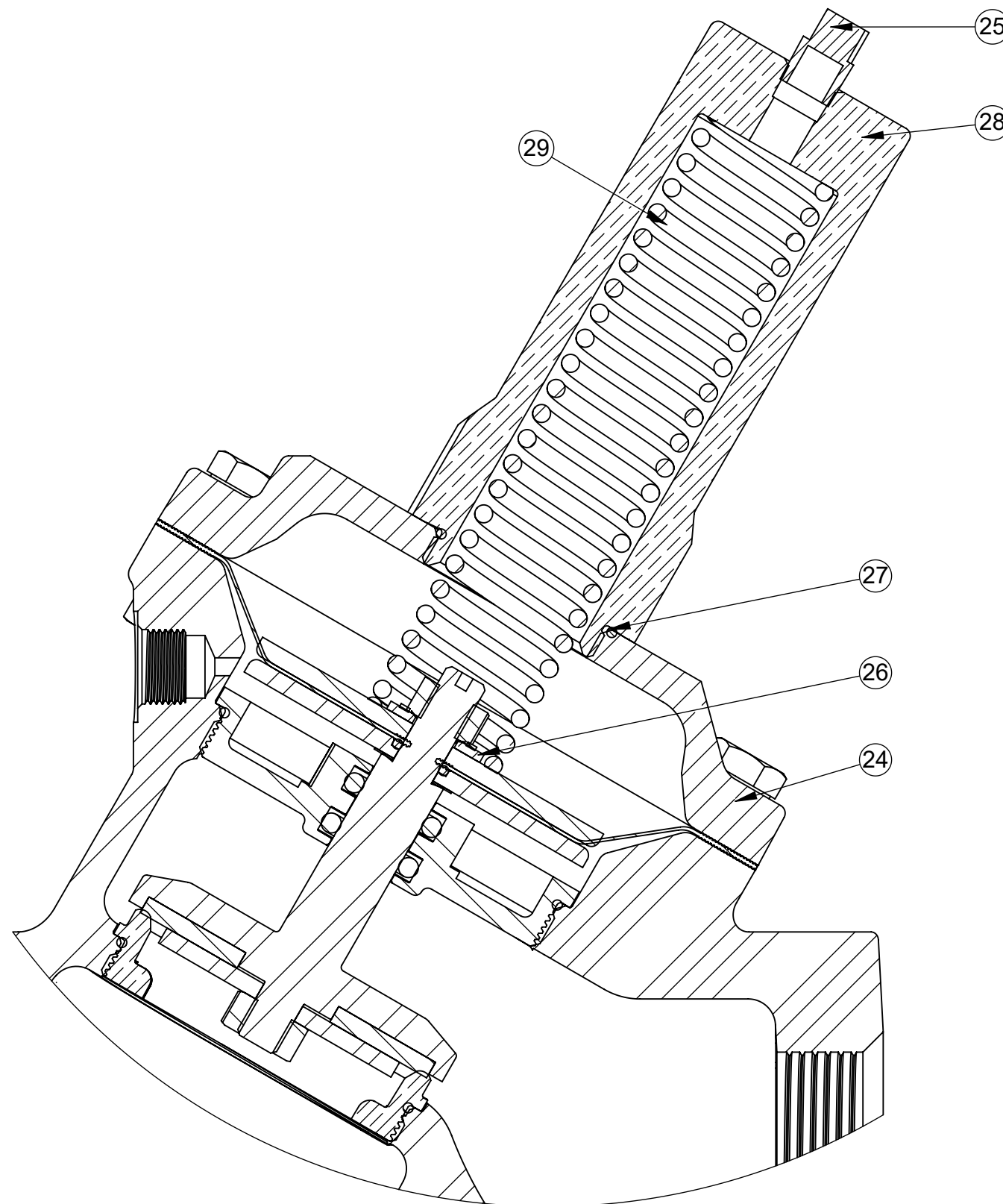

1072485 (VAVF-0002-90000) (2" NPT)
SPRING ASSIST CLOSED

NORMALLY CLOSED MODEL				
ITEM NO.	DESCRIPTION	STD	PART NUMBER	QTY.
19	PIPE PLUG (1/4"NPT)	PLATED STEEL	* 1071918 (PLZ-0008)	1
20	COMBO. SHAFT, NORMALLY CLOSED	STAINLESS STEEL	* 44017-01 (425-LL)	1

SPRING ASSIST OPEN MODEL				
ITEM NO.	DESCRIPTION	STD	PART NUMBER	QTY.
21	WASHER, CENTERING	BRASS	* 1074436 (426-V)	1
22	SPRING, COMPRESSION	STAINLESS STEEL	* 1078692 (426-S)	1
23	PIPE PLUG (1/4"NPT)	PLATED STEEL	* 1071918 (PLZ-0008)	1

SPRING ASSIST CLOSED MODEL				
ITEM NO.	DESCRIPTION	STD	PART NUMBER	QTY.
24	CAP, SPRING ASSIST CLOSED	CAST IRON	* 1074284 (425-CA)	1
25	PIPE PLUG (1/8" NPT)	BRASS	* 1071903 (PLB-0007)	1
26	WASHER	BRASS	* 1074083 (421-AH)	1
27	O-RING, 2-025	BUNA	* 1071677 (ORB-025)	1
28	NUT, SPRING RETAINER	BRASS	* 1074431 (425-TTA)	1
29	SPRING	STAINLESS STEEL	* 1074429 (425-SSB)	1

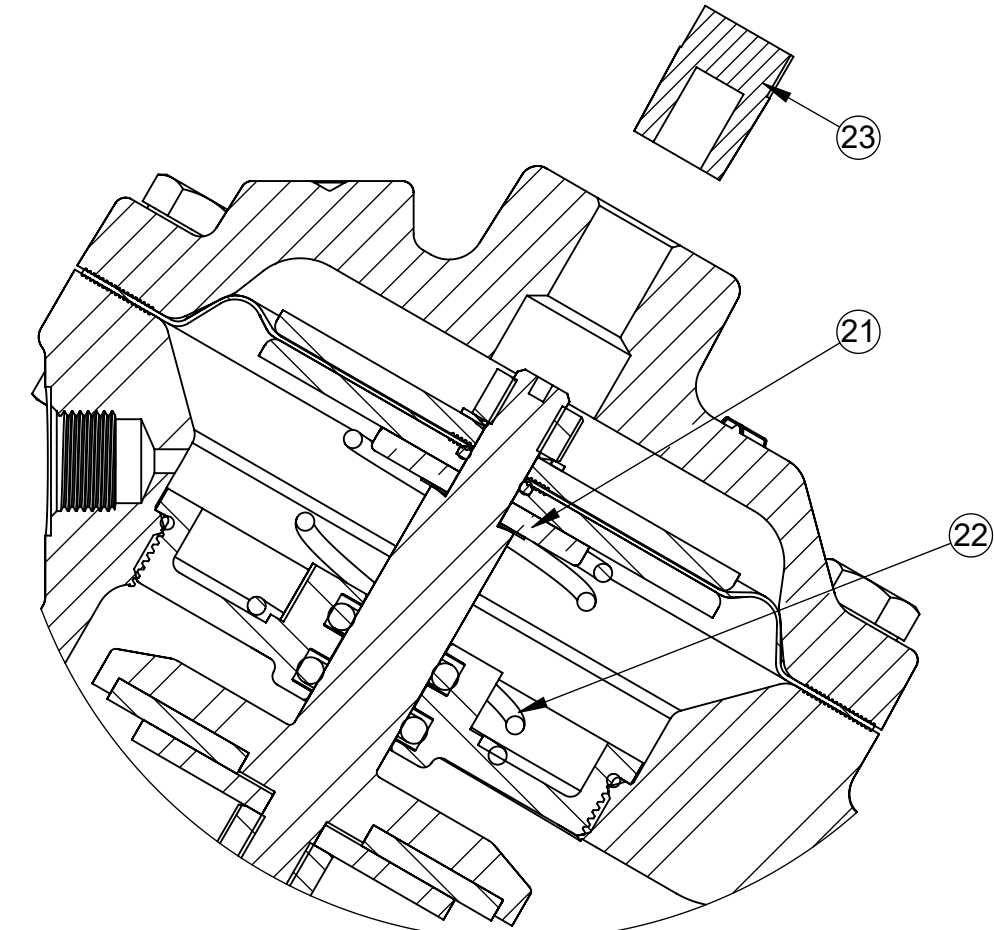

1072484 (VAVF-0001-90000) (2" NPT)
SPRING ASSIST OPEN

TORQUE TABLE		
ITEM #	DESCRIPTION	TORQUED TO (+/- 10%)
28	NUT, SPRING RETAINER	120 IN/LBS

CONVERSION KITS	
DESCRIPTION	PART NO.
CONVERSION KIT (SPRING ASSIST CLOSED) CONSISTS OF STANDARD ITEM NO'S 24 THRU 29	1070507 (AV5-SCC)
CONVERSION KIT (SPRING ASSIST OPEN) CONSISTS OF STANDARD ITEM NO'S 21, 22	1070508 (AV5-SO)

REPAIR PARTS KITS	
DESCRIPTION	PART NO.
INT. PARTS KIT (NORM. CLOSED) CONSISTS OF STANDARD ITEM NO'S 3, 5(2), 15, 17, 20	1070505 (AV5-RG)
INT. PARTS KIT (SPRING ASSIST CLOSED) CONSISTS OF STANDARD ITEM NO'S 26, 27, 29	1070506 (AV5-SC)
INT. PARTS KIT (SPRING ASSIST OPEN) CONSISTS OF STANDARD ITEM NO'S 21, 22	1070508 (AV5-SO)

NOTE:

1. SPRING ASSIST CLOSED MODEL CANNOT BE COMBINED WITH LIMIT STOP MODEL.
2. VALVES AVAILABLE WITH B.S.P.T. END CONNECTIONS.

THIS DOCUMENT IS SOLELY THE PROPERTY OF AQ-MATIC REPRODUCTION, USE DISCLOSURE, OR TRANSMISSION OF THIS DOCUMENT OR DETAILS CONTAINED HEREIN, IN PART OR IN WHOLE, IS PROHIBITED WITHOUT THE WRITTEN CONSENT OF AQ-MATIC ENGINEERING. THIS DOCUMENT AND ANY COPIES SHALL BE RETURNED TO AQ-MATIC UPON WRITTEN REQUEST.

INTERPRET DIMENSIONS AND TOLERANCES PER ASME Y14.5M -1994

UNLESS OTHERWISE SPECIFIED:
DIMENSIONS ARE IN INCHES [mm]
CORNER FILLETS R.005-020 [127-508]
TOLERANCES:
ANGLES : ± 1°
1 PLACE .X: ± .100 [2.54]
2 PLACE .XX: ± .010 [0.25]
3 PLACE .XXX: ± .005 [0.13]

THIRD ANGLE PROJECTION				
APPROVALS	DATE	 AQ-MATIC VALVES AND CONTROLS		
DRAWN	1/22/21			
CHECKED BY				
APPROVED				
DESCRIPTION		CATALOG SHEET, VAV5		
SIZE	C	DWG NO.	1077637	
SCALE	1:2	SOLIDWORKS FORMAT	SHEET 2 OF 2	
		REV.	P	