

REPAIR PARTS KITS		
DESCRIPTION	PART NO.	
DIAPHRAGM & SEAL KIT CONSISTS OF ITEM NO'S 4, 5(2), 6, 8, 9(2), 10, 17, 18	1070109 (AV6-RA)	1070510 (AV6-RAHT)
	INCLUDES DISC P/N 1074392 (HYCAR) AND DIAPHRAGM P/N 1074374 (BUNA N)	INCLUDES DISC P/N 1074393 (TEFLON) AND DIAPHRAGM P/N 1074376 (FKM)
INT. PARTS KIT (NORM. OPEN) CONSIST OF STANDARD ITEM NO'S 3, 8, 13, 14, 15, 16	10705011 (AV6-RF)	
SEAT (ITEM NO. 7)	1074409 (426-MO)	

ASSEMBLY TOOLS	
DESCRIPTION	PART NO.
FOR INSTALLATION & REMOVAL OF SEAT (ITEM #7) (TOOL NOT SHOWN)	1074411 (426-MT)
FOR INSTALLATION & REMOVAL OF SHAFT GUIDE (ITEM #3) (TOOL NOT SHOWN)	1- 1/8" HEX SOCKET

- NOTE:
1. AMERICAN NATIONAL STANDARD TAPER PIPE THREADS (NPT) PER ANSI B2.1-1968.
 2. VALVES AVAILABLE WITH B.S.P.T. END CONNECTIONS.

TORQUE TABLE		
ITEM #	DESCRIPTION	TORQUED TO (+/- 10%)
3	SHAFT GUIDE	200 IN/LBS
5	UPPER NUT	140 IN/LBS
5	LOWER NUT	140 IN/LBS
7	SEAT	200 IN/LBS
11 & 12	NUT, HEX SCREW	140 IN/LBS

REVISIONS				
ECN	REV.	DESCRIPTION	DATE	APP'D
1829	R	REVISED COMPONENTS, UPDATED CATALOG SHEET	1/22/21	TRK
2016	S	REVISED COMPONENTS, ELIMINATE ITEM 7 FROM REPAIR KITS	2/25/22	TRK

NORMALLY OPEN (STANDARD) MODEL				
ITEM NO.	DESCRIPTION	STD.	PART NUMBER	QTY.
1	VALVE BODY MACHINED, CI	2" NPT	* 1074343 (426-A8)	1
		2 1/2" NPT	1081559 (426-A10)	
2	CAP, NPT	CAST IRON	* 1081560 (426-C)	1
3	SHAFT GUIDE	STAINLESS STEEL	* 43849	1
4	DIAPHRAGM, 426	BUNA	* 1074374 (426-FB)	1
		FKM	1074376 (426-FV)	
5	NUT, HEX, 5/16" - 24	STAINLESS STEEL	* 1263853 (RMET)	2
6	DISC, 426	HYCAR	* 1074392 (426-JH)	1
7	SEAT, 426, BRASS	BRASS	* 1074409 (426-MO)	1
8	O-RING, 2-144	FKM	* 1071809 (ORV-144)	1
9	O-RING, 2-114	ALFAS	* 1071662 (ORA-114)	2
10	O-RING, 2-233	FKM	* 1071826 (ORV-233)	1
11	BOLT, HEX HD, 5/16"-18X1 3/8"LG	PLATED STEEL	* 1072401 (SCZ-0015)	6
12	HEX NUT, 5/16" - 18	PLATED STEEL	* 1071657 (NUZ-0011)	6
13	DISC PLATE	STAINLESS STEEL	* 4510417	1
14	DIAPHRAGM PLATE, UPPER	STAINLESS STEEL	* 1074371 (426-DA)	1
15	COMBINATION SHAFT, 426	STAINLESS STEEL	* 44021 (426-L)	1
16	DIAPHRAGM PLATE, LOWER	STAINLESS STEEL	* 1074372 (426-DAA)	1
17	O-RING, 2-011	FKM	* 1071786 (ORV-011)	1
18	LOCKWASHER, 5/16", INTERNAL TOOTH	STAINLESS STEEL	* 1073590 (WAS-0009)	1

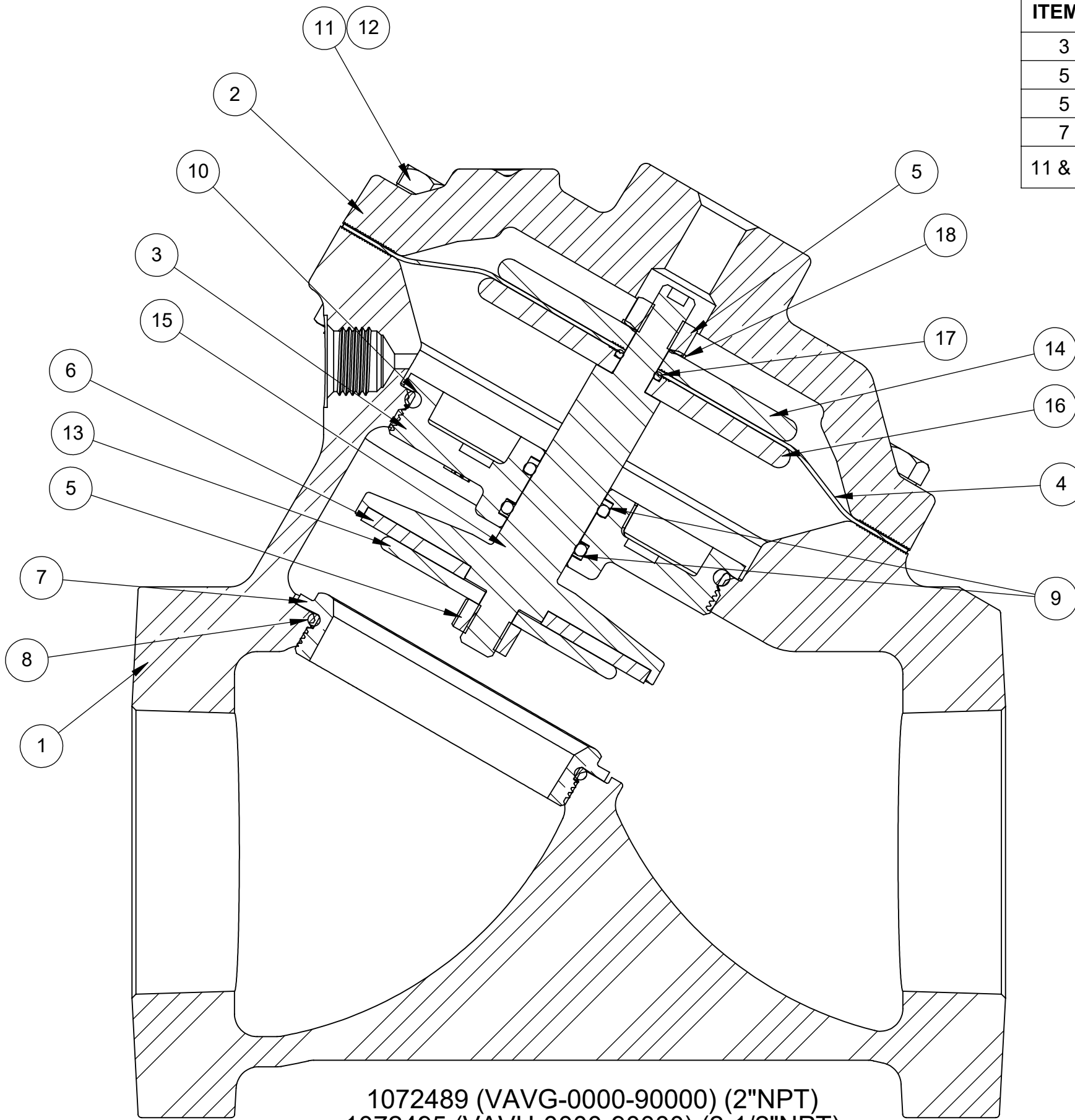

1072489 (VAVG-0000-90000) (2"NPT)
1072495 (VAVH-0000-90000) (2-1/2"NPT)

NORMALLY OPEN (STANDARD)

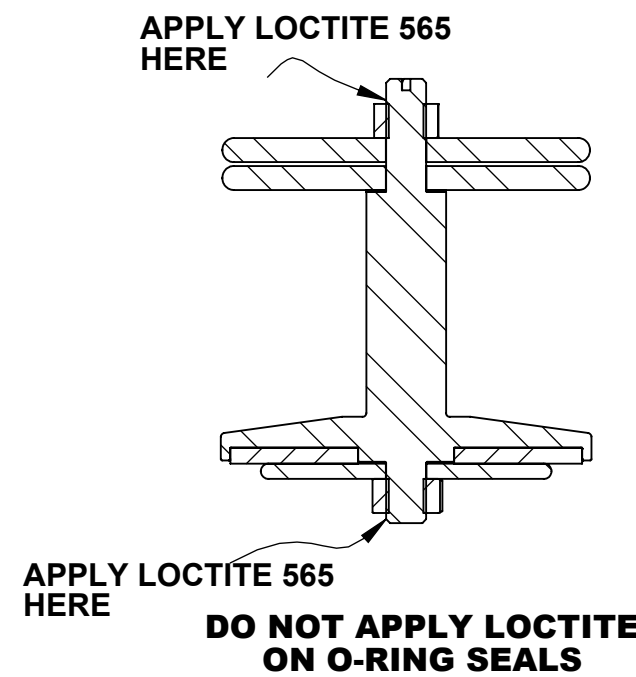

SEE REVERSE SIDE FOR CONFIGURATION OPTIONS

THIS DOCUMENT IS SOLELY THE PROPERTY OF AQ-MATIC REPRODUCTION, USE DISCLOSURE, OR TRANSMISSION OF THIS DOCUMENT OR DETAILS CONTAINED HEREIN, IN PART OR IN WHOLE, IS PROHIBITED WITHOUT THE WRITTEN CONSENT OF AQ-MATIC ENGINEERING. THIS DOCUMENT AND ANY COPIES SHALL BE RETURNED TO AQ-MATIC UPON WRITTEN REQUEST.

INTERPRET DIMENSIONS AND TOLERANCES PER ASME Y14.5M -1994

UNLESS OTHERWISE SPECIFIED:
DIMENSIONS ARE IN INCHES [mm]
CORNER FILLETS R.005-.020 [127-508]
TOLERANCES:
ANGLES: ±1°
1 PLACE .X: ±.100 [2.54]
2 PLACE .XX: ±.010 [0.25]
3 PLACE .XXX: ±.005 [0.13]

THE COMPONENT OR PRODUCT DESCRIBED IN THIS DOCUMENT MUST COMPLY WITH RoHS 3 EU (EUROPEAN UNION) DIRECTIVE 2015/863

THIRD ANGLE PROJECTION	
APPROVALS	DATE
DRAWN TRK	1/22/21
CHECKED BY	
APPROVED	



DESCRIPTION CATALOG SHEET, VAV6 DIAPHRAGM VALVE STANDARD MODEL		REV. S
SIZE C	DWG NO. 1077638	
SCALE 1:2	SOLIDWORKS FORMAT	SHEET 1 OF 2

REVISIONS				
ECN	REV.	DESCRIPTION	DATE	APP'D
1829	R	REVISED COMPONENTS, UPDATED CATALOG SHEET	1/22/21	TRK
2016	S	REVISED COMPONENTS, ELIMINATE ITEM 7 FROM REPAIR KITS	2/25/22	TRK

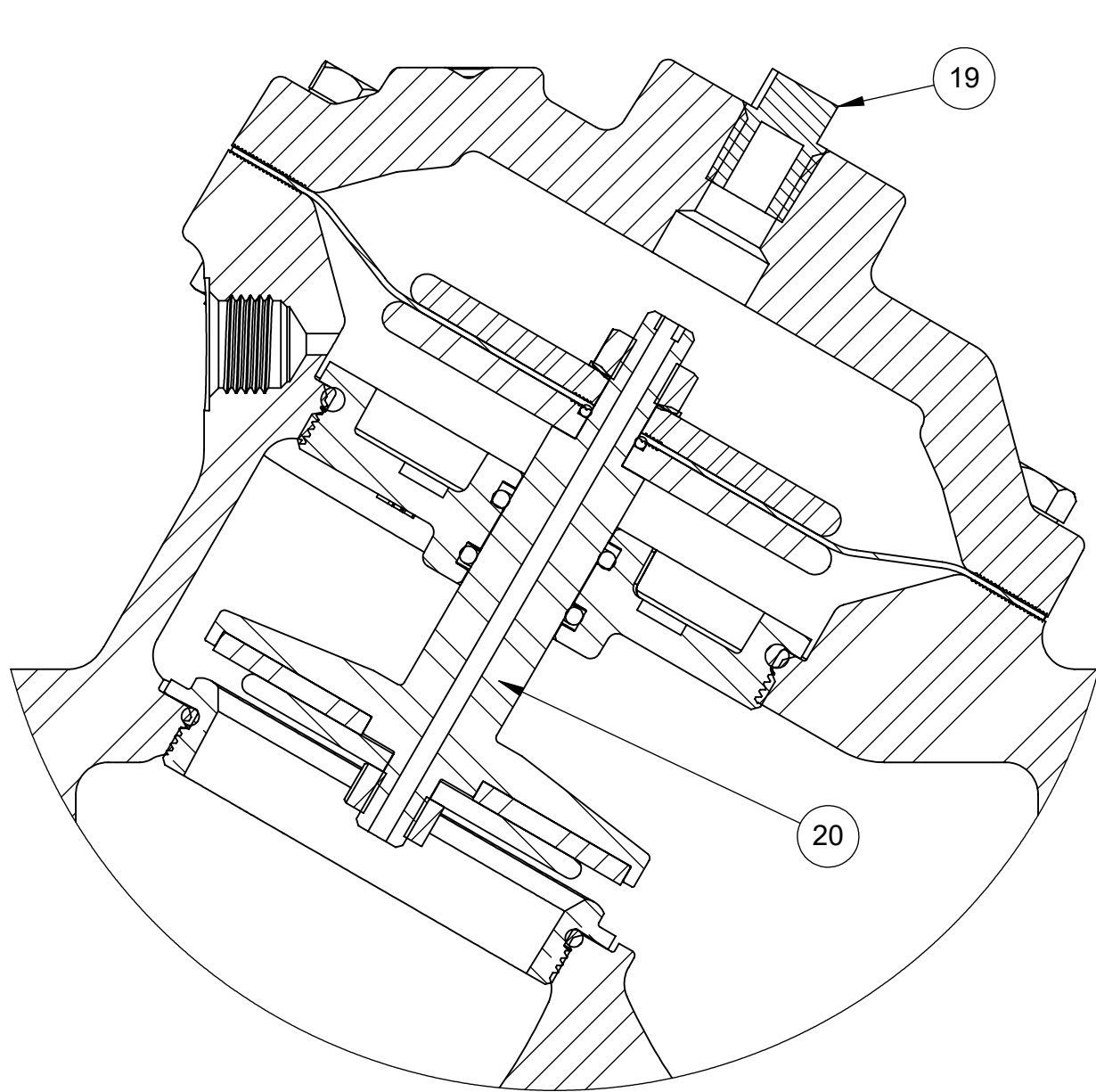

3026107 (VAVG-0030-90000) (2" NPT)
1080794 (VAVH-0030-90000) (2-1/2" NPT)

NORMALLY CLOSED

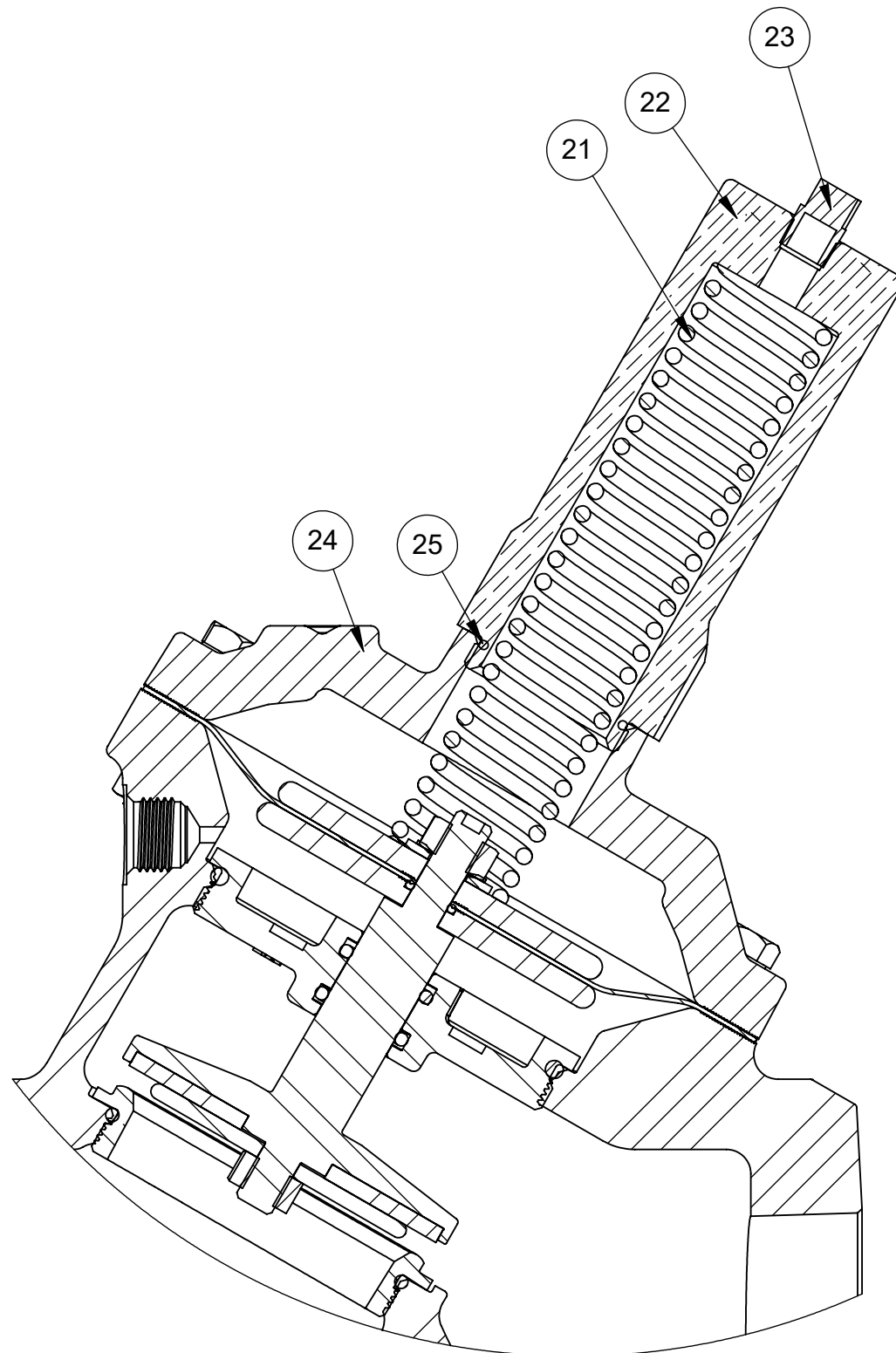

1077120 (VAVG-0002-90000) (2" NPT)
1072498 (VAVH-0002-90000) (2-1/2" NPT)

SPRING ASSIST CLOSED

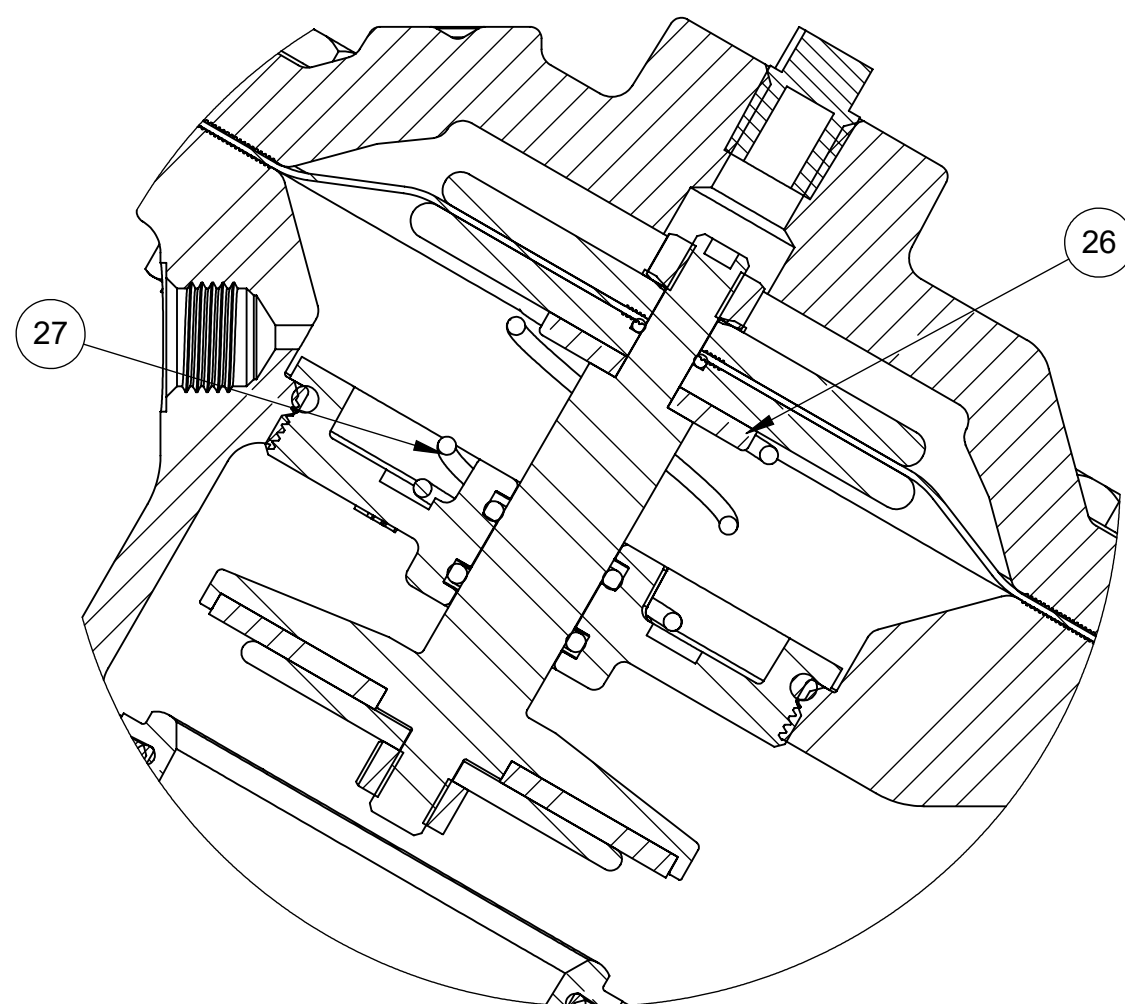

1072491 (VAVG-0001-90000) (2" NPT)
1072497 (VAVH-0001-90000) (2-1/2" NPT)

SPRING ASSIST OPEN

NORMALLY CLOSED MODEL				
ITEM NO.	DESCRIPTION	STD.	PART NUMBER	QTY.
19	MALE PIPE PLUG 1/4" NPT	PLATED STEEL	* 1071918 (PLZ-0008)	1
20	COMBINATION SHAFT, NC	STAINLESS STEEL	* 44021-01 (426-LL)	1

SPRING ASSIST CLOSED MODEL				
ITEM NO.	DESCRIPTION	STD.	PART NUMBER	QTY.
21	COMPRESSION SPRING	STAINLESS STEEL	* 1074429 (426-SSB)	1
22	SPRING RETAINER NUT	BRASS	* 1074331 (425-SD)	1
23	MALE PIPE PLUG 1/8" NPT	BRASS	* 1071903 (PLB-0007)	1
24	CAP, SAC	CAST IRON	* 1074352 (426-CC)	1
25	O-RING, 2-025	BUNA -N	* 1071677 (ORB-025)	1

SPRING ASSIST OPEN				
ITEM NO.	DESCRIPTION	STD.	PART NUMBER	QTY.
26	CENTERING WASHER	BRASS	* 1074436 (426-V)	1
27	SPRING, COMPRESSION	STAINLESS STEEL	* 1078692 (426-S)	1

REPAIR PARTS KITS	
DESCRIPTION	PART NO.
INT. PARTS KIT (NORM. CLOSED) CONSISTS OF STANDARD ITEM NO'S 3, 8, 13, 14, 16, 20	1070512 (AV6-RG)
INT. PARTS KIT (SPRING ASSIST CLOSED) CONSISTS OF STANDARD ITEM NO'S 21, 25	1070513 (AV6-SC)
INT. PARTS KIT (SPRING ASSIST OPEN) CONSISTS OF STANDARD ITEM NO'S 26 & 27	1070515 (AV6-SO)

CONVERSION KITS	
DESCRIPTION	PART NO.
CONVERSION KIT (SPRING ASSIST CLOSED) CONSISTS OF STANDARD ITEM NO'S 21 THRU 25	1070514 (AV6-SCC)
CONVERSION KIT (SPRING ASSIST OPEN) CONSISTS OF STANDARD ITEM NO'S 26 & 27	1070515 (AV6-SO)

TORQUE TABLE		
ITEM#	DESCRIPTION	TORQUED TO (+/- 10%)
22	RETAINER NUT	140 IN/LBS

SEE REVERSE SIDE FOR
STANDARD NORMALLY OPEN MODEL

THIS DOCUMENT IS SOLELY THE PROPERTY OF AQ-MATIC REPRODUCTION, USE DISCLOSURE, OR TRANSMISSION OF THIS DOCUMENT OR DETAILS CONTAINED HEREIN, IN PART OR IN WHOLE, IS PROHIBITED WITHOUT THE WRITTEN CONSENT OF AQ-MATIC ENGINEERING. THIS DOCUMENT AND ANY COPIES SHALL BE RETURNED TO AQ-MATIC UPON WRITTEN REQUEST.

INTERPRET DIMENSIONS AND TOLERANCES PER ASME Y14.5M -1994

UNLESS OTHERWISE SPECIFIED:
DIMENSIONS ARE IN INCHES [mm]
CORNER FILLETS R.005-020 [127-508]
TOLERANCES:
ANGLES : ± 1°
1 PLACE .X: ± .100 [2.54]
2 PLACE .XX: ± .010 [0.25]
3 PLACE .XXX: ± .005 [0.13]

THE COMPONENT OR PRODUCT DESCRIBED IN THIS DOCUMENT MUST COMPLY WITH RoHS 3 EU (EUROPEAN UNION) DIRECTIVE 2015/863

THIRD ANGLE PROJECTION	
APPROVALS	DATE
DRAWN	1/22/21
CHECKED BY	
APPROVED	

AQ-Matic AQ-MATIC VALVES AND CONTROLS

DESCRIPTION CATALOG SHEET, VAV6
DIAPHRAGM VALVE STANDARD MODEL

SIZE C DWG NO. 1077638 REV. S

SCALE 1:2 SOLIDWORKS FORMAT SHEET 2 OF 2